

# OS3 Control Panel

## Technical Information & Operating Instructions



### Introduction

The SE Controls OS3 range of control systems include a built, tested and EN12101-10 certified control panel. This panel is specifically designed for smoke control systems and is intended for use exclusively with SE Controls equipment.

It is essential that these systems are not used for any other applications or in conjunction with products from other manufacturers without prior approval from SE Controls.

Only qualified and competent personnel should carry out the installation and maintenance of this equipment.

The Installer and end user are requested to read, and understand this document. It must be retained with the panel for future reference and be made available to persons installing, or servicing the panel.

### Application

OS3 is a modular smoke control and environmental ventilation system. It consists of a centralised coordination module (the coordinator) and between 1 and 16 zones. Larger systems can be constructed by linking together multiple coordinators.

The coordinator controls power and data to the networked system, fully monitoring primary (mains) and secondary (battery<sup>1</sup>) power supplies. The OS3 system intelligently monitors the systems current requirements and determines how and when the MCPs can call on this power to activate AOVs.

<sup>1</sup>Batteries supplied separately

# Contents

## 1. General Information

1.1.	General Safety Information	4
1.2.	Health and Safety	4
1.3.	Environment	4
1.4.	User Responsibilities	4
1.5.	Maintenance	5
1.6.	Installation and Connection	5
1.7.	Fault Finding	5
1.8.	Pre Commissioning	5
1.9.	Contact Information	5
2.0.	Certification	5

## 2. Specification

2.1.	Device Overview	6
2.2.	Manual Control Points (MCP)	7
2.3.	Three Wire Manual Control Points (MCP)	8
2.4.	External Indication	9
2.5.	Smoke Detector	9
2.6.	Back Up Battery	9
2.7.	Activation Keys	9
2.8.	Volt Free Relay indication	9
2.9.	Required Cable Types	9

## 3. Installation and Commissioning

3.1.	Pre-Installation	10
3.2.	Mounting :Location	10
3.3.	Fixing	10
3.4.	Coordinator Connection Detail	11
3.5.	Loop In/Loop Out	11
3.6.	OS3 Connection at the MCP	11
3.7.	Smoke Detector to MCP Wiring	12
3.8.	Fire Alarm Connection	13
3.9.	Actuator Connection	14
3.10.	Actuator Mode Jumper	15
3.11.	Jumpers on the Coordinator	15
3.12.	OS3 Continuity Check	15-16

3.13.	Option: OSLink Connections	16
3.14.	Option: Relay Output to Ancillary Equipment	17
3.15.	Repeater Panel Connections	17
3.16.	Single Floor Activation Interlock	18
3.17.	Fitting of MCPs	18
3.18.	Operation of the MCP Cover Flap	18
3.19.	Mains Power Supply	19

## 4. The OS3 NV Board

4.1.	OS3 Coordinator 2 Zone and 4 Zone Options	20
4.2.	NV2/NV4 Smoke Detector and Fire Alarm	21
4.3.	NV2/NV4 Actuator Connection	21
4.4.	NV2/NV4 Three Wire MCP Connection	22
4.5.	NV2/NV4 Auxillary Connections	23
4.6.	5-Level Digital Input Example	24

## 5. Fault Codes

5.1.	Coordinator Flash Codes	25-26
5.2.	MCP Flash Codes	27

## Important Notices

- The equipment has no mains on/off switch and is intended for permanent connection only.
- Do NOT allow abuse or mishandling of the device.
- Do NOT adjust or alter the device or its enclosure including labelling/markings.
- Do NOT use this controller for any other purpose other than that intended by the manufacturer.
- Do NOT allow installation of this equipment by persons not electrically qualified.
- Damage to the equipment due to failure to test the electrical integrity of external wiring will invalidate any warranties.
- Failure to install the device in accordance with the manufacturer's instructions will invalidate any warranties.
- Failure to follow current electrical regulations governing the installation of fixed equipment can lead to prosecution and may invalidate any warranties.
- Unless otherwise indicated, you must not adjust or remove existing manufacturers cabling or use terminal outputs or inputs for purposes other than their design without written authorization from SE Controls.
- Consumable items e.g. fuses and batteries where replacement is needed must be replaced with parts of equivalent manufacturing standard/ compliance and rating.

**SE Controls accepts no liability for failure to comply with these statements or the installation and operation guidance in the following sections of this guide and reserves the right to invalidate the warranty of the controller**

**SE Controls reserves the right to introduce any modifications and improvements to the contents of this publication without the obligation of giving prior notice.**

# 1. General Information

## 1.1. General Safety Information



Read and observe the information contained in these instructions.

Please keep these safety instructions for future reference and maintenance. Reliable operation and the prevention of damage and risks are only granted if the equipment is assembled carefully and the settings are carried out according to these instructions and to the operating instructions of the drives.

Please observe the exact terminal assignment, the minimum and maximum power ratings (see technical data) and the installation instructions.

## 1.2. Health and Safety



**Electrical Safety:** Warning 230 V ac mains supply can cause death, serious injury or considerable material damage. Disconnect the equipment from the power supply at all poles before opening, assembling or carrying out any work.

**Electrical safety of batteries:** Short circuiting of the lead acid batteries can cause high currents to flow which can cause rapid heating and a fire risk. Take care to avoid this when transporting and handling batteries. Keep batteries disconnected during installation and modification of the installation.

**Competence:** This equipment is designed for professional installation only by qualified, trained and safety conscious electricians or skilled and trained staff with considerable knowledge of electrical equipment installation. These instructions must be followed and retained for future reference.

**Application:** This equipment is designed exclusively for the purposes of controlling automatically opening smoke ventilation equipment.



**Personal Protective Equipment:** It is recommended that suitable PPE is worn at all times during the installation and connection of actuator products in accordance with a recommended safe system of work.



**Handling and storage:** This equipment is heavy. Care must be taken in transportation to the installation location and during fitting. The equipment must not be dropped, impacted, allowed to get wet or abused in any other way. Mishandling can result in serious damage to the housing and the components therein.



**Risk of crushing:** this equipment can automatically close windows and other appliances without warning. Beware risk of serious injury from crushing of hands or fingers.

## 1.3. Environment



This equipment is fitted with a pair of lead acid batteries which contain a corrosive gel. These batteries must be regularly inspected for damage and condition. Lead acid batteries are classified as hazardous waste and must be disposed of by an authorised and licensed recycler. They must not be disposed of in household waste or 'general waste' skips.



Redundant electronic products are classified as hazardous waste under the WEEE regulations (Waste Electrical and Electronic Equipment). Electronic parts must be disposed by an authorised and licensed recycler. They must not be disposed of in household waste or 'general waste' skips.

If recycling facilities are not locally available, contact SE Controls who can arrange for recycling and disposal of old electronic products.

## 1.4. User Responsibilities

### United Kingdom Only:

BS 7346-8:2013 is a British Standard code of practice for the planning, design, installation, commissioning and maintenance of smoke control systems. Section 9 of the standard (Maintenance and Servicing) states that frequent inspection of the system should be undertaken by a named suitably-trained member of the premises management team.

Routine inspection of the system should be carried out in accordance with BS 9999:2017, Annex V.

### For countries outside the United Kingdom:

Please check with the local fire authority in your area regarding smoke control legislation, different user responsibilities may apply.

**Smoke control equipment should only be maintained by a competent person with specialist knowledge of smoke control systems and sufficient information regarding the system.**

## 1.5. Maintenance



An smoke control system should be checked and serviced periodically in accordance to local smoke control legislation.

Smoke control systems have to be serviced and checked for defects at least once per year by an authorised, trained and competent person.

**Within the UK a suitable service contract with SE Controls is recommended for this purpose, (see section 1.8 for contact information).**

All batteries need to be checked to see if they are within specification and in good condition at least once a year and replaced at least every **THREE YEARS** (please observe the battery commissioning label).



Ensure that supply voltage and batteries are disconnected before any maintenance work or mechanical/electrical alterations are made.

**The system must be protected against unintentional start-up!**

After maintenance, modification or repair the system must be functionally retested.

Compatibility; this equipment should only be used to operate with motors and other products approved by SE Controls. No liability will be accepted and neither guarantee nor service is provided if unapproved products are used in conjunction with this equipment.

## 1.6. Installation and Connection



Installation should be carried out by an authorised, trained and competent electrician. Ensure correct cable type is used throughout the installation. All low voltage cables are to be routed separately from mains voltage cables and other electrically noisy cables. Flexible cables must not be plastered over and freely suspended cables must be provided with strain relief. Cables must be installed in such a way that they cannot be sheared, twisted, pierced or otherwise damaged during installation or use. Junction boxes should be accessible for inspection and maintenance.

**The OS3 Control System is designed solely for internal installation.**

**The installation of the panel is not recommended at altitudes exceeding 2,000 metres.**

**Do not attempt to install or alter the installation of the panel whilst connected to the power supply.**

**Connections to auxiliary inputs (AI1,AI2) and auxiliary outputs (AO,VSW) used for non fire safety related functions (e.g. Day-to-day switches, rain sensor) do not require fire rated cables. The cable length for these auxiliary inputs and outputs must be less than 30 metres.**

## 1.7. Fault Finding



In the unlikely event that a problem occurs with the control panel, users are urged to contact SE Controls for assistance.

If the system operates from mains power but when mains power is removed will not operate from batteries, it is possible that the batteries will require replacement.

There are no user repairable parts. Fault rectification must only be carried out by authorised and competent persons.

## 1.8. Pre-Commissioning

Prior to commissioning, use a dry cloth to ensure that the panel is clean and free of any dirt or debris that could hinder its functionality.

## 1.9. Contact Information

**For sales, technical support and maintenance please contact:**

SE Controls  
Lancaster House  
Wellington Crescent  
Fradley Park  
Lichfield  
Staffordshire  
WS13 8RZ

**Tel:** 01543 443060

**E-mail:** info@secontrols.com

**Website:** www.secontrols.com

## 2.0. Certification

SE Controls hereby certify that the parts and services detailed hereon have been manufactured, inspected, tested and supplied in accordance with the conditions and requirements of the procedures as documented in the Company Quality Assurance System to ensure conformance with SE Controls' specifications, and with the contract or order conditions of our BS EN ISO9001:2015 registration.

Our equipment is built and tested in accordance with the requirements of EN12101-10:2005/AC:2007. Certification may be provided on request.

## 2. Specification

### 2.1. Device Overview

<b>Part Number</b>	FCS13350000 - OS3 Control Panel (0 Zone) 380x305x122 RAL 7035 Grey FCS13350002 - OS3 Control Panel (2 Zone) 380x305x122 RAL 7035 Grey FCS13350004 - OS3 Control Panel (4 Zone) 380x305x122 RAL 7035 Grey
<b>Dimensions</b>	382 x 305 x 122 mm (H x W x D)
<b>Mass Approx.</b>	4.1 kg
<b>Supply</b>	230 V ac 50/60 Hz. (±10%) from a 5 A unswitched spur
<b>Power Consumption</b>	Max. 500 V A
<b>Typical Output Voltage (Mains Power)</b>	Typical Output Voltage (Mains power, max load 7.0A) Nominal 24.0 V <b>NV Link 2/4</b> Max 5A for 180 seconds Peak current can exceed 5 A for a short duration
<b>Typical Output Voltage (No Mains)</b>	Nominal 24.0 V Max. 28.8 V Min. 18.5 V
<b>Maximum Current (Mains and Batteries)</b>	Max 7.0 A for 180 seconds Peak current can exceed 7.0 A for a short duration
<b>Auxiliary Outputs</b>	VC, VD, VE, Nominal 24.0 V, 100mA / 40mA
<b>Battery Backup</b>	2 x 12 V dc 12.0 Ah sealed lead-acid sold seperately)
<b>Expected Battery Life</b>	3 Years @ 25°C
<b>Real Time Clock Battery Life</b>	10 Years
<b>Cable Entries</b>	For ease of installation, cable entries are via up to 6 off 20 mm cable glands mounted either side, plus up to 12 off 20 mm top mounted cable glands and/or one rear entry slot for concealed connection
<b>IP Rating</b>	IP30
<b>Overvoltage Category</b>	2
<b>Pollution Degree</b>	2
<b>Humidity Range</b>	10% to 90% Non-condensing
<b>Storage</b>	-20°C to + 50°C
<b>Operating Temperature</b>	-5°C to + 40 °C
<b>Battery Standby Time<sup>1</sup></b>	72 Hours

<sup>1</sup>On mains failure, average auxiliary current must be less than 20mA to achieve 72 Hours BBU

## 2.2. Manual Control Point (MCP)

<b>Part Number (OS3 Standard MCP)</b>	FCS00300041 (Module Assembly) FCS00300040 (Adaptor Plate) FCS00300043 (Module & Adaptor Plate Assembly)
<b>Part Number (OS3 Tamper Proof MCP)</b>	FCS00300042 (Module Assembly) FCS00300040 (Adaptor Plate) FCS00300044 (Module & Adaptor Plate Assembly)
<b>Reset / Activation Keys</b>	FCS00200024 (MCP Dumb Reset Key) FCS00200033 Activation Key - Open Only
<b>Dimensions</b>	87 x 87 x 54 mm (H x W x D Approx.)
<b>Mass Approx</b>	0.1 kg
<b>Supply</b>	20 V-29 V
<b>Typical Output Voltage</b>	Nominal 24.0 V Max. 28.8 V Min. 18.5 V
<b>Maximum Current</b>	Max 3.0 A for 180 seconds <sup>1</sup> Peak current can exceed 3.0 A for a short duration
<b>IP Rating</b>	IP20
<b>Humidity Range</b>	10 to 90% Non-Condensing
<b>Storage</b>	- 20°C to 75°C
<b>Operating Temperature</b>	- 5°C to 40°C

<sup>1</sup>Can be upgraded to 6A via Engineer Tools

### 2.3. Three Wire Manual Control Point (MCP)

<b>Part Number (Standard MCP)</b>	FCS00300045 (Module Assembly) FCS00300018 (Adaptor Plate) FCS00300047 (Module & Adaptor Plate Assembly)
<b>Part Number (Tamper Proof MCP)</b>	FCS00300046 (Module Assembly) FCS00300018 (Adaptor Plate) FCS00300048 (Module & Adaptor Plate Assembly)
<b>Reset / Activation Keys</b>	FCS00200024 (MCP Dumb Reset Key) FCS00200033 Activation Key - Open Only
<b>Dimensions</b>	87 x 87 x 54 mm (H x W x D Approx.)
<b>Mass Approx</b>	0.1 kg
<b>Supply</b>	20 V-29 V
<b>IP Rating</b>	IP20
<b>Humidity Range</b>	10 to 90% Non-Condensing
<b>Storage</b>	- 20°C to 75°C
<b>Operating Temperature</b>	- 5°C to 40°C

## 2.4. External Indication

Lamp	Detail
Fault	Flashes when a fault is present (see fault codes)
Fault Condition	Lit when the controller is activated by a fire input or via a MCP open signal
Standby	Lit when healthy and mains supply is connected.

**Note: The functions of the LEDs reflect active and healthy relays.**

## 2.5. Smoke Detector

<b>Part Number</b>	ADA55000318 (OSLoop/OS3 Smoke Detector Head)
<b>Part Number</b>	ADA45681200 (OSLoop/OS3 Smoke Detector Base)

## 2.6. Back Up Battery

<b>Part Number</b>	ABB00660016 (12 Volt 12 AH Back Up Battery) <sup>1</sup>
--------------------	--

<sup>1</sup>x2 Batteries required - order separately

## 2.7. Reset/Activation Keys

<b>Part Number</b>	FCS00200024 (MCP Dumb Reset Key)
<b>Part Number</b>	FCS00200033 (Activation Key - Open Only)

## 2.8. Volt Free Relay Indication

Terminal	Description
(Activated) CM	Activated relay common
(Activated) NC	Activated relay normally closed (opens when activated)
(Activated) NO	Activated relay normally open (closes when activated)
(Activated) LP	Do not use
(Healthy) CM	Healthy relay common
(Healthy) NC	Healthy relay normally closed (opens when healthy)
(Healthy) NO	Healthy relay normally open (closes when healthy)
(Healthy) LP	Do not connect

**The function of these relays can be modified by parameter changes.**

## 2.9. Required Cable Types

Cabling For	Minimum Number of Cores	Required Cable Type
<b>Mains Supply Cable</b>	2 Core + Earth x 1.5 mm <sup>2</sup>	FP Plus or equivalent
<b>OS3 MCP</b>	4 Core + Earth x 2.5 mm <sup>2</sup>	FP Plus or equivalent
<b>24V dc Actuator</b>	2 Core + Earth x 1.5 mm <sup>2</sup>	FP Plus or equivalent
<b>OS3/OSLoop Smoke Detector</b>	2 Core + Earth x 1.5 mm <sup>2</sup>	FP Plus or equivalent
<b>OSlink Network Cable</b>	2 Core + Earth x 1.5 mm <sup>2</sup>	FP Plus or equivalent

All cabling should be in accordance with relevant standards and regulations for electrical installation such as BS 7671.



To ensure optimal performance and safety, please be advised that the **maximum allowable cable length for the panel is 30 metres** for auxillary connections (Rain Sensor, Day-to-Day Switch)..

# 3. Installation and Commissioning

## 3.1. Pre-Installation

After unpacking the controller, use a Pozidriv screwdriver to unfasten each of the screws and allow removal of the lid of the control unit. It is recommended that the lid be temporarily placed back inside the packaging to prevent damage to the paint finish.

**Note:** The coordinator requires two 12 A Hr sealed lead acid batteries, supplied separately.



**The OS3 Control System is designed solely for internal installation.**

## 3.2. Mounting Location

The coordinator is environmentally rated at IP30 and hence should not be located where exposure to damp/moisture or significant amounts of dust is likely. In particular, do not mount the controller in extreme environments such as cold rooms/boiler rooms and those areas classified as having potentially explosive atmospheres.

Mount the coordinator on a level secure surface. Ensure that when correctly fixed, the surface can support the weight of the controller. The controller can be mounted on any vertical surface such as a wall.

Typically, the OS3 system is installed as a smoke shaft controller and consequently a good mounting point for the coordinator is at the top or bottom of the building, within the electrical riser.

The coordinator should not be installed in an air tight environment.

## 3.3. Fixing

Hold the body of the coordinator up against the surface to which it is to be fixed. Ensure that it is mounted at least 50 mm above the floor level to reduce the possibility of water damage.

Mark through the three keyed fixing holes with a marker pen and place the coordinator body to one side. Drill appropriately sized pilot/fixing holes and use suitable plastic plugs/cavity fixings where appropriate. Note that it is recommended that 40 mm No.8 pan head self tapping screws are used to secure the body in place.

Fit the three screws into place leaving about 5 mm protruding from the wall. Offer up the coordinator body to these screws and ensure that all three key-ways are fully engaged. Fully tighten the screws so that the coordinator body is fixed firmly into place.

It is recommended that the required number of cable entry glands is now assessed. A combination of 6 knock-outs and fully open gland holes are provided for this purpose.

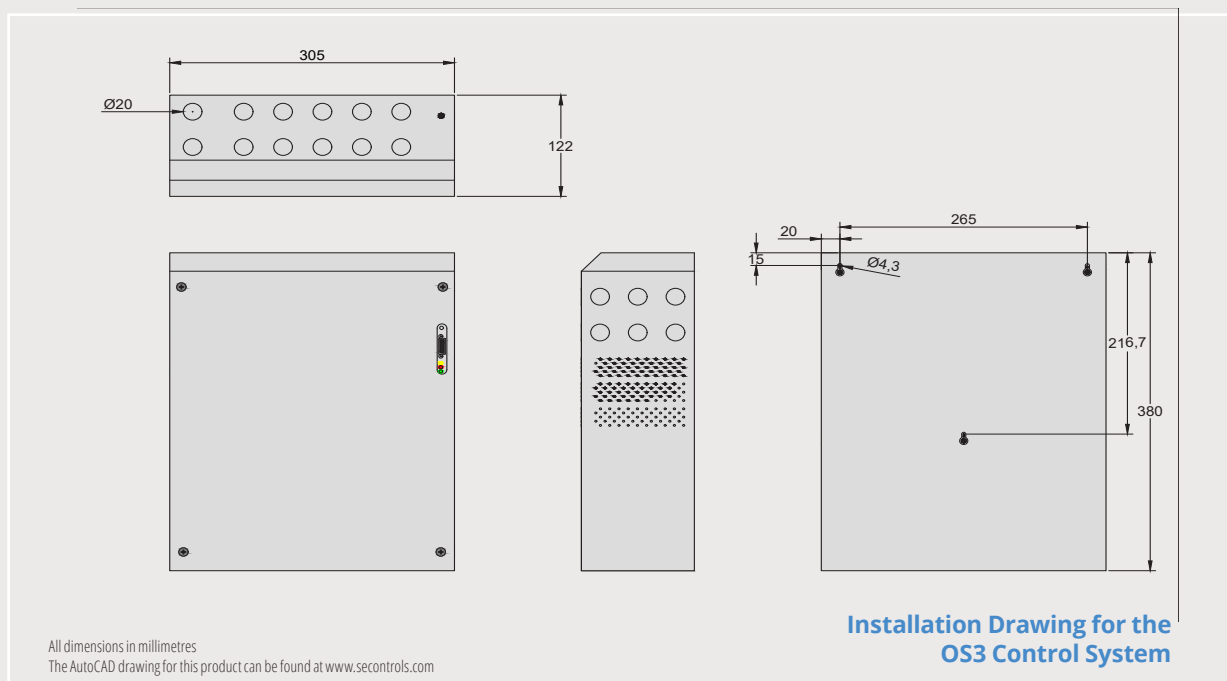

### 3.4. Coordinator Connection Detail

Except for the 230 V ac incoming power supply, all the field wiring connections are grouped logically on the top edge of the main PCB (see illustration below).

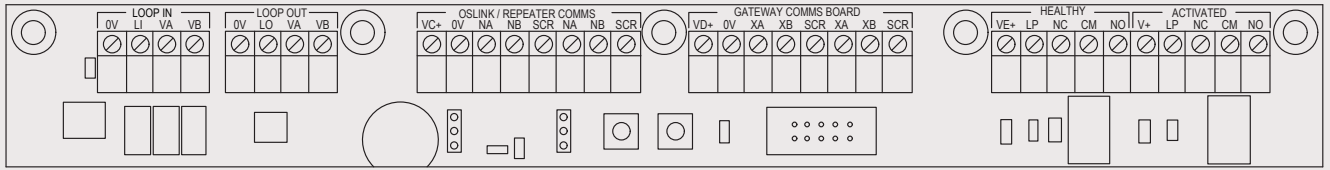

Note: that all terminals are suitable for solid cable with a maximum cross-sectional area of 2.5 mm<sup>2</sup>.

### 3.5. Loop In/Loop Out

The main OS3 cables are connect to/from the coordinator as follows:

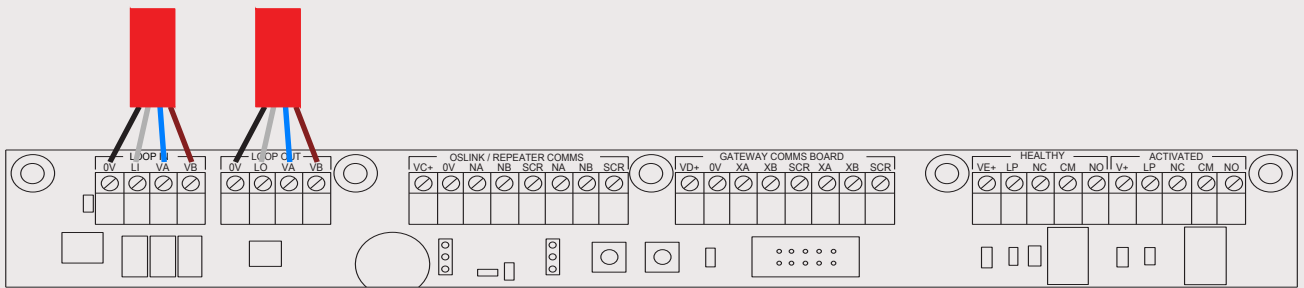

Ensure a consistent colour scheme is used all around the loop

There is no need to identify the incoming and outgoing cables as the MCP will function equally well with the in and out connections swapped.

### 3.6. OS3 Connection at the MCP

The main OS3 cables connect coordinator to MCP and MCP to MCP as follows:

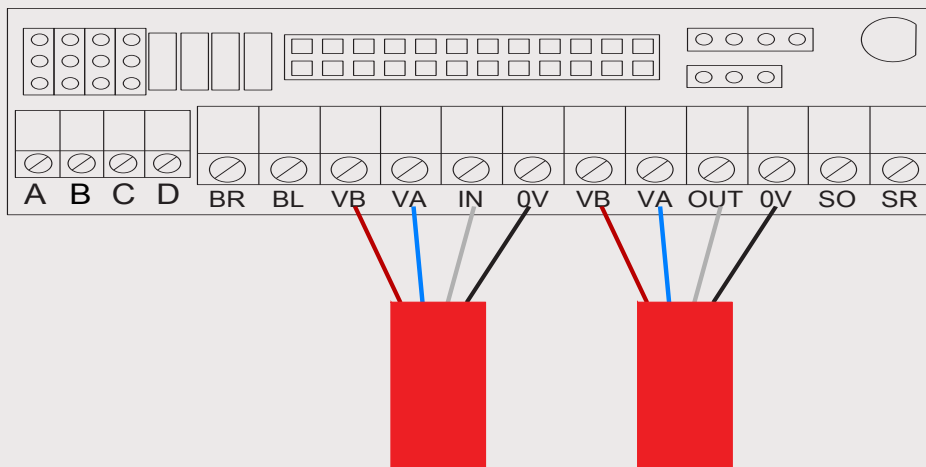

Ensure a consistent colour scheme is used all around the loop

There is no need to identify the incoming and outgoing cables as the MCP will function equally well with the in and out connections swapped.

\*The cable outer screen is left unconnected

### 3.7. Smoke Detector to MCP Wiring

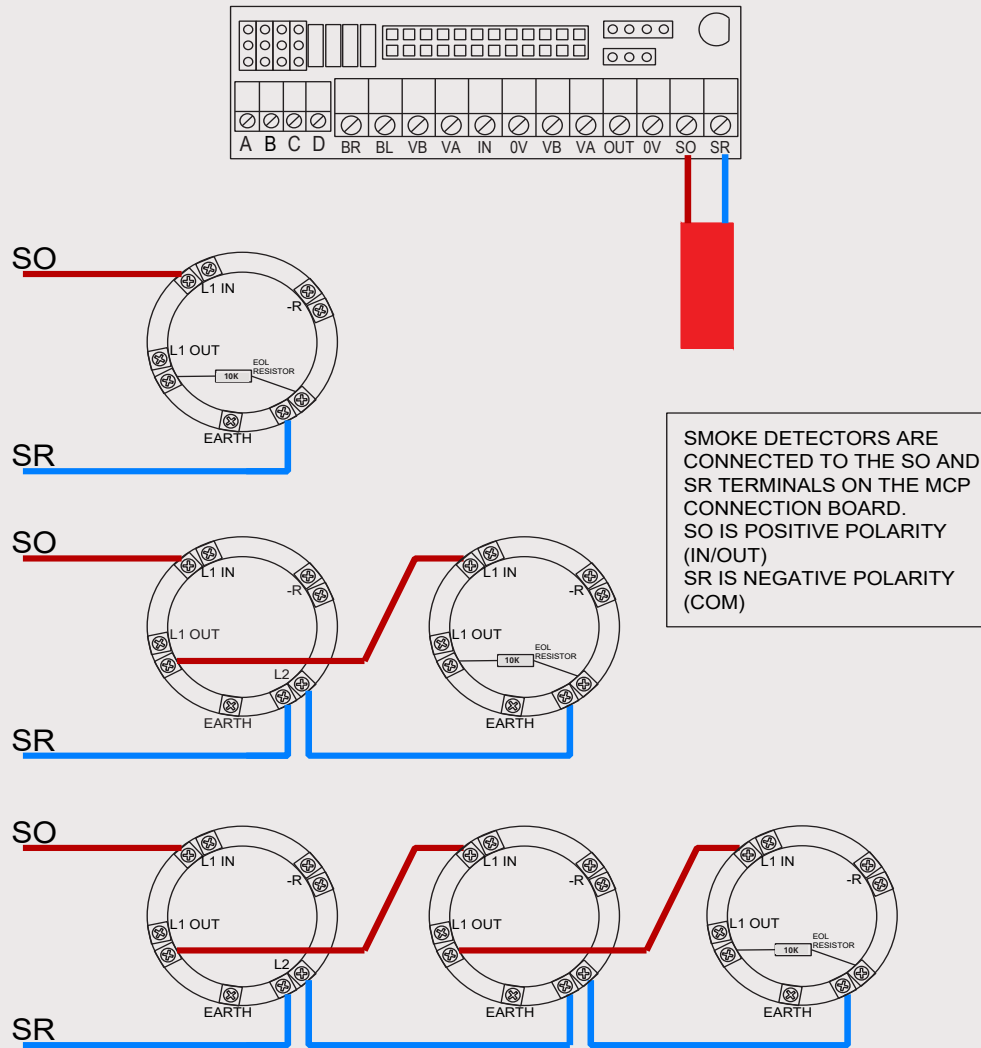

The illustration above shows SE Controls preferred timesaver bases - connection to other makes of smoke detectors will be similar.

For end of line monitoring to function properly, the smoke detector bases must be wired in series, where the end of line 10K resistor is wired to the last smoke detector base as shown above. Removal of the smoke head will break the connection from IN to OUT, and an alarm raised. Smoke detector bases should not be of the type with a diode between IN and OUT.

Any cable shield is left unconnected. For smoke detectors, use 10K terminator resistors **FCS00301001**.

### 3.8. Fire Alarm Connection

Where the system is activated by fire alarm interface, the SO and SR terminals are connected to the interface via an **ACG50001595** contact monitoring module.

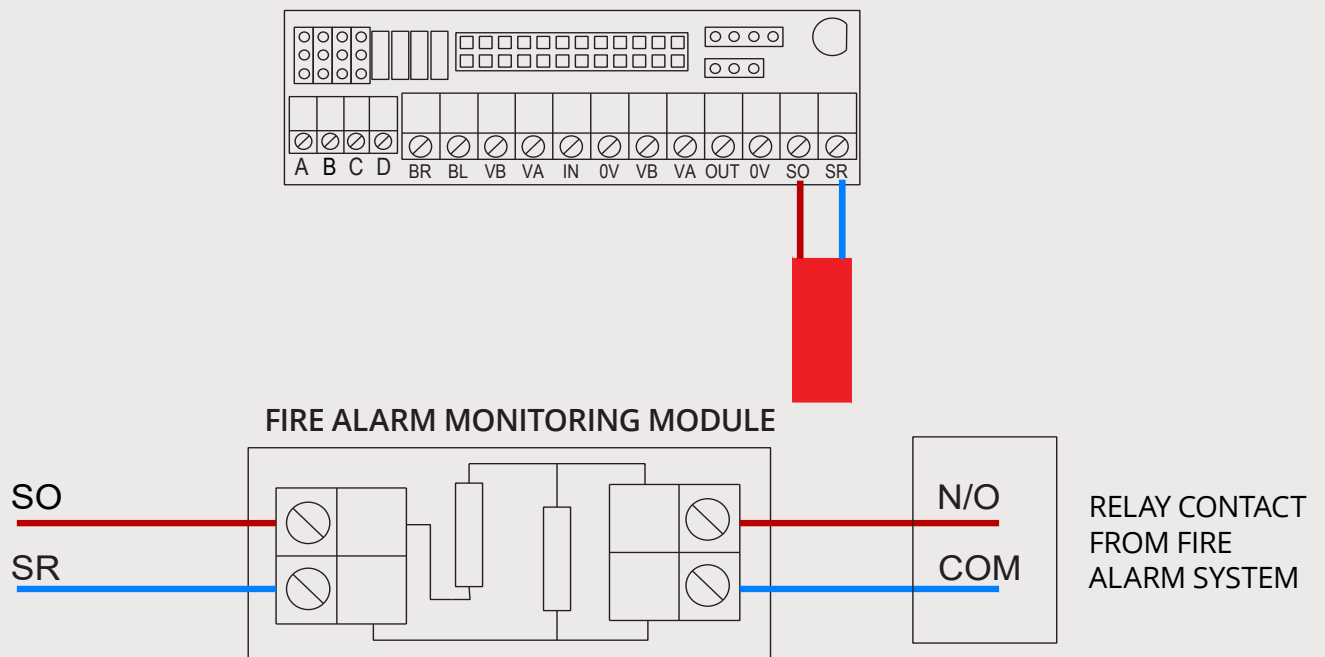

**The contact monitoring module should be installed as close to the fire alarm interface as possible (commonly inside the same enclosure), to allow monitoring of the full length of the cable to the MCP.**

This connection is not polarity sensitive. Any cable screen is left unconnected.

### 3.9. Actuator Connection

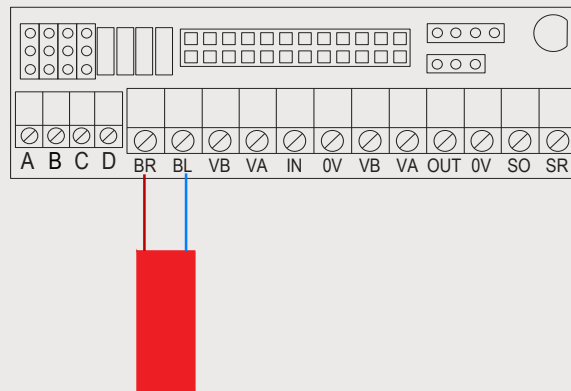

The actuators are connected to the BR and BL terminals on the MCP connection board.

If connection is via a junction box within the smoke shaft, a high temperature rated ceramic terminal block is preferred.

Some actuators require a 1k ohm terminating resistor **ACR00149694**, which if needed, should be fitted close to the actuator. Other actuators have inbuilt resistors or similar circuitry and do not require a resistor to be fitted.

Any cable screen is left unconnected.



Please check Actuator compatibility matrix for OS3  
Actuator mode configuration may be changed via the Engineering Tools

### 3.10. Input/Output Selection Jumpers

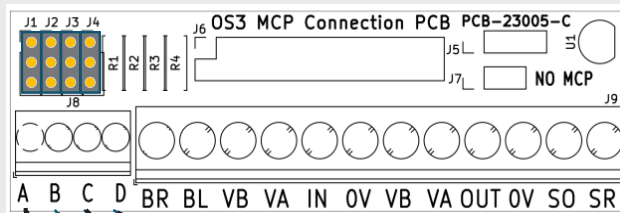

	A	B	C	D	Application
	AI1	-0 V	AI2	-0 V	Two Analog inputs Inputs selectable as resistance or 0-10 V
	AI1	AO	AI2	0 V	Two Analog inputs (Resistance or 0-10 V) One Analog output (0-10 V)
	- LOAD +				Monitored Output (low current) Output by Analog Out – 0-10 V Load current -> AI1, 0.1 V/mA
			- LOAD +		Monitored Output (VSW, low current) Output PSW – 0 V/24 V Load current -> AI2, 0.1V/mA
			- LOAD +		Monitored Output (VSW, high current) Output VSW – 0V/24 V Load current -> AI2, 0.05 V/mA
		0 V		+24 V VSW	Switched Power Output VSW - 0 V/24 V
		0 V	RNS	+24 V VSW	Powered Sensor (e.g Rain Sensor) RNS signal on AI2 VSW can power down on mains failure
	U	Y	COM	+24 V	0-10 V Actuator (e.g. Belimo), Set position (Y) =Analog out, Position feedback (U) -> AI1 , Load current -> AI2, 0.05 V/mA, +24 V by PSW

### 3.11. Jumpers on the Coordinator

Three jumpers are present on the coordinator:

		Up	Down
<b>CN6</b>	Sounder on coordinator	DIS - Disabled	SND - Enabled (default())
<b>CN7</b>	OSLink line terminator resistor	CLR - Disabled (default)	TERM - Enabled
<b>CN15</b>	Realtime clock (RTC) battery	BAT - Enabled (default)	Reset to the RTC

CN6 can be changed to disable the sounder on the coordinator.

Other jumpers rarely need changing, and should only be used on instruction from the SE Controls Technical Support team.

### 3.12. OS3 Continuity Check

It is recommended that this check is performed after wiring all the MCP connection boards, but before connecting the OS3 cables at the coordinator:

Set the jumper on every MCP connection board to 'No-MCP' (right). This connects IN and OUT terminals

Do not refit the MCPs to any connection board.

### 3.12. OS3 Continuity Check, (cont.)

Using a multi-meter set to measure ohms; check the continuity of each wire in turn (VA, VB, in/out, 0 V) from the outgoing cable to the return cable. Typical 2.5 mm<sup>2</sup> cables have a resistance of 7.4 ohms per kilo-meter, so the expected resistance loop resistance should be less than two ohms.

Also check for high resistance (>100 k ohm) from every conductor to every different one.

This test detects most loop wiring faults, but cannot detect when a connection has been swapped and swapped back.

### 3.13. Option: OSLink Connections

On some systems, the OSLink/Repeater connector is used to communicate with repeater panels or to other OS3 coordinators. Connections NA and NB are duplicated to allow two cable connections.

**Terminals**

OS3	Coordinator	OS2	Repeater Panel	Cable Colours
NA	NA	NTA	NTA	Blue
NB	NB	NTB	NTB	Brown
VC+	VC+	-	V+	Black
OV	OV	SCR	OV	Grey

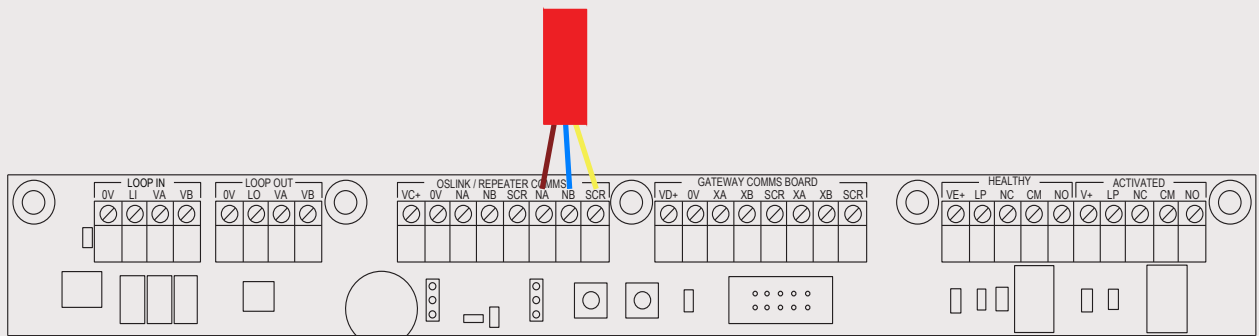

Coordinator to coordinator connections do not require power, and may be wired in two core plus earth. In this case, connect the protective screen to 0 V at both ends.

### 3.14. Option: Relay Output to Ancillary Equipment

The OS3 activation relay provides a volt free contact to external equipment.

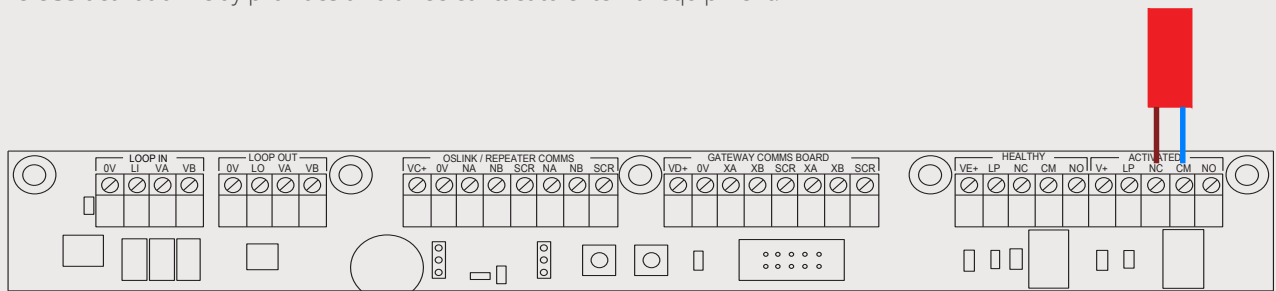

### 3.15. Repeater Panel Connections

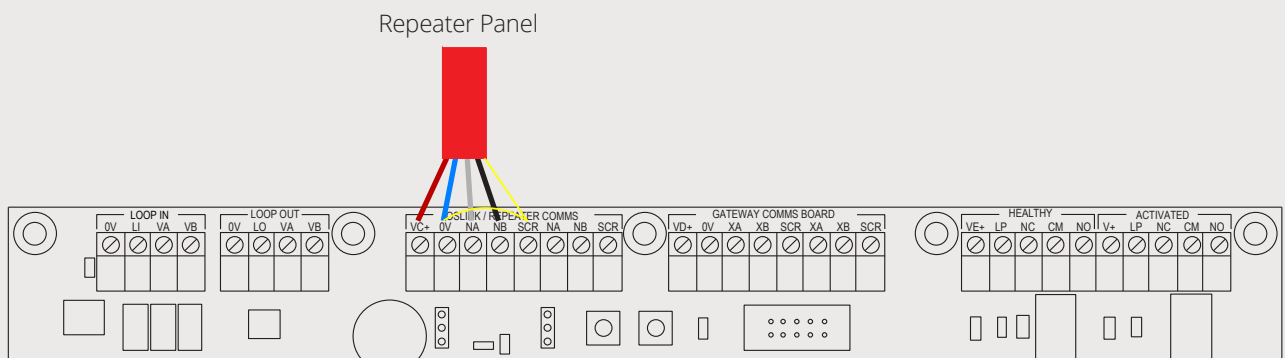

The repeater panel uses a four-way connection to carry data and power.

Four-way cables should have the protective screen linked to 0 V at one end only.

### 3.16. Single Floor Activation Interlock

Zones 0-12 are now pre-configured as single floor activation group. Any smoke detector active input or MCP red button activation in this group will inhibit smoke detector and red buttons in all others in the group. This prevents more than one vent opening due to stray smoke. Zones 0-12 should be used for smoke shaft vents only, or modify the parameters [ZSSD], [ZSZI] and [ZSIB] to change the single floor group (normally all the same value)

**Parameter [ZSSD]** controls the zones which when active will start the single floor interlock.

**Parameter [ZSSI]** controls the zones which have the SD/FA input disabled by an activation in [ZSSD].

**Parameter [ZSIB]** defines the zones which have the red button disabled by an activation in [ZSSD].

Do not install stairwell or independent AOV controls within the [ZSSD] group as their activation could prevent stack operation.

### 3.17. Fitting the MCPs

Ensure both battery and mains power is turned off at the coordinator before plugging the MCP to its connection board.

Ensure the MCP PCB is the correct type – MCP circuit boards are coloured purple.

Before fitting each MCP, check that the 'NO-MCP' jumper on the connection board is not in the enable (right) position.

Check that none of the 24 pins on the MCP are bent or damaged before plugging the MCP onto the connection board.

**Note:** Connecting and disconnecting MCPs on a powered OS3 system can potentially cause irreversible damage to the MCP.



OS3 MCP Circuit Boards are coloured purple

### 3.18. Operation of the MCP Cover Flap

If the cover flap has been lifted, it cannot be closed unless a reset key is inserted in the slot on the underside of the MCP. Never insert a screwdriver or other objects into the reset key slot.

Take care in opening the cover flap if the underside screws have not been secured.

### 3.19. Mains Power Supply

**Note:** Mains electrical installation must be carried out by a certified competent person, and in compliance with current IEE wiring regulations

The mains power is wired from a local fused outlet (or preferably a fused double poll isolating key switch) to the live, neutral and earth terminals of the supply using FP Plus or flexible three core cable. If using FP Plus, the earth connection should be sleeved green/yellow. Ensure the supply is protected by a 5 amp fuse or breaker.

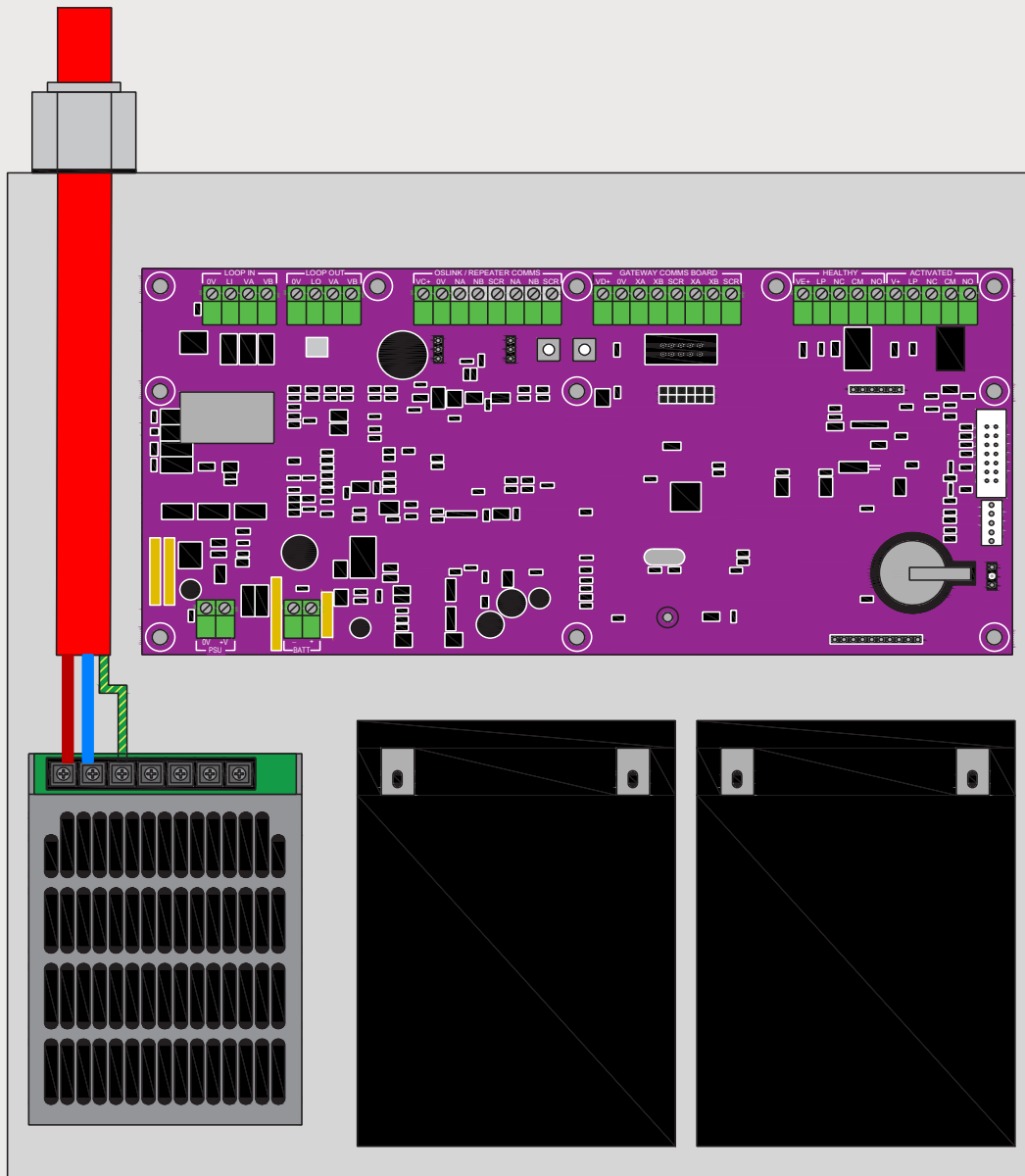

The power supply earth terminal also connects to the chassis - ensure this earth connection is properly made.

## 4. The OS3 NV Board

### 4.1. OS3 Coordinator 2 Zone and 4 Zone Options

The OS3 coordinator has an optional additional circuit board installed in the coordinator enclosure. This allows up to two/four additional zones to be controlled directly from the coordinator by an additional circuit board installed in the coordinator.

These provide functionality identical to the MCPs, excluding MCP buttons and sounder.

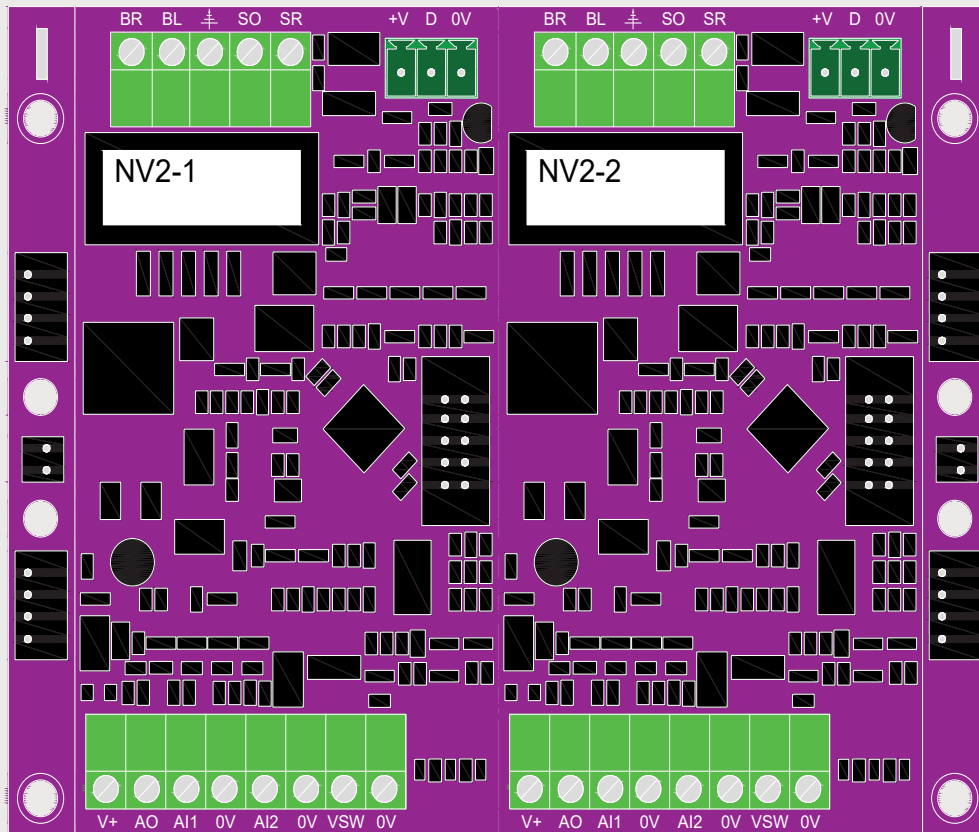

Connectors X1-X7 are for internal connections only.

## 4.2. NV2/NV4 Smoke Detector and Fire Alarm

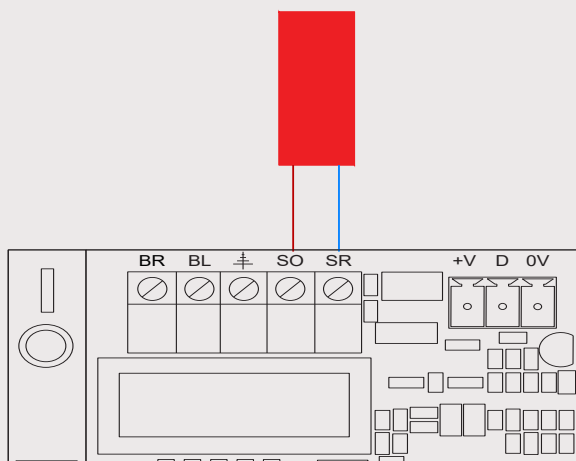

SO/SR terminals can connect to either two wire smoke detector(s) or fire alarm relay. End-of-line termination is required as motors connected to the MCP (See 3.7 and 3.8).

The cable shield wire is not connected.

## 4.3. NV2/NV4 Motor Connection

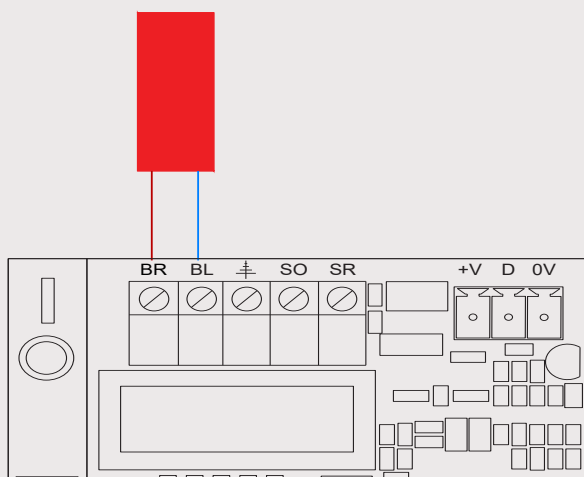

Motor output is 24 V switched polarity output similar to the MCP motor outputs. Motors with low standby current may require an additional end-of-line resistor. (See 3.9 Actuator Connection).

As zones using the internal board are not subject to voltage drops around the loop cables, this motor drive is especially suited to high current loads (e.g. Roof Vent actuators).

The cable shield wire is not connected.

#### 4.4. NV2/NV4 Three Wire MCP Connection

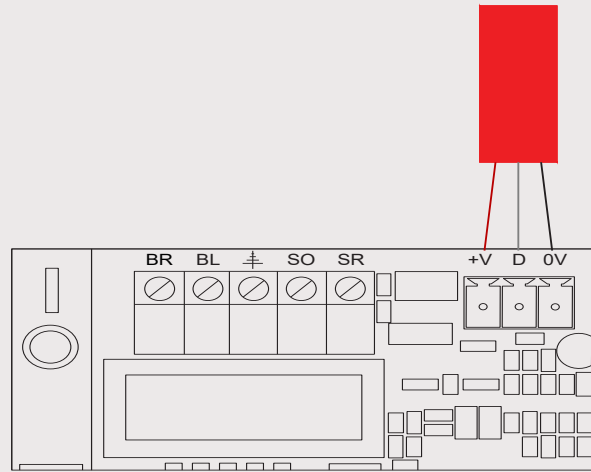

NV2/NV4 Zones requiring status indications or activate/reset buttons may be connected to an external three wire MCP (**FCS00300047** or **FCS FCS00300048**) using the 3 wire port. These 3 wires are connected to the similar connector on the three wire MCP.

The 3 wire MCP only supports buttons and LED indication, and does not support smoke detector or fire alarm inputs, motor drive, fault flash codes, temperature sensing and auxiliary inputs.

The cable shield wire is not connected.

## 4.5. NV2/NV4 Auxillary Connections

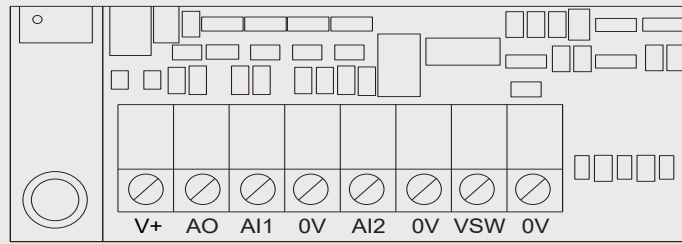

Auxiliary connection port provides general purpose inputs and outputs. Typical uses of these are day-to-day switches, rain sensors, other environmental sensors, mode switches, etc.

Power provides by V+ and VSW terminals total current must not exceed 1.0 Amp. VSW can be programmed to power down after mains failure. Total system average current drawn under mains fail condition will be drawn from the battery and must be considered by the system designer to maintain the required battery standby duration.

Terminal	Function	Specification
V+	Permanent +24 V power out, derived from battery or mains. Overload protected by self- resetting fuse.	+24 V +15%/-25% Max 1 Amp.
AO	Analog output – 0-10 V.	Max +/- 50mA, Accuracy +/-0.2V
AI1 AI2	Two Analog inputs operate in voltage or resistance mode: Voltage mode : 0 - 10 V mode Resistance mode : enable internal 10K pullup to 10 volts.	V mode : +/-2%
VSW	Switched programmable +24 V power out, derived from battery or mains. Overload protected by self resetting fuse, with trip detection.	+24 V +15%/-25% Max 1 Amp.

Analog inputs in resistive mode can also be used as simple digital or 5 level digital.

Simple mode, a button, switch or relay contact connects AI1 or AI2 to 0 V.

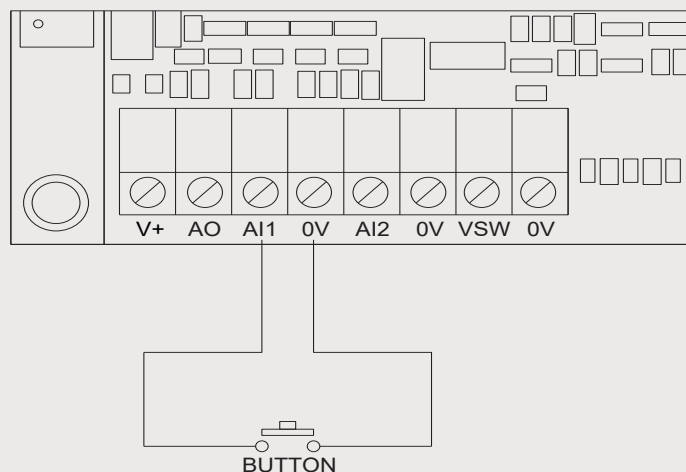

## 4.6. 5-Level Digital Input Example

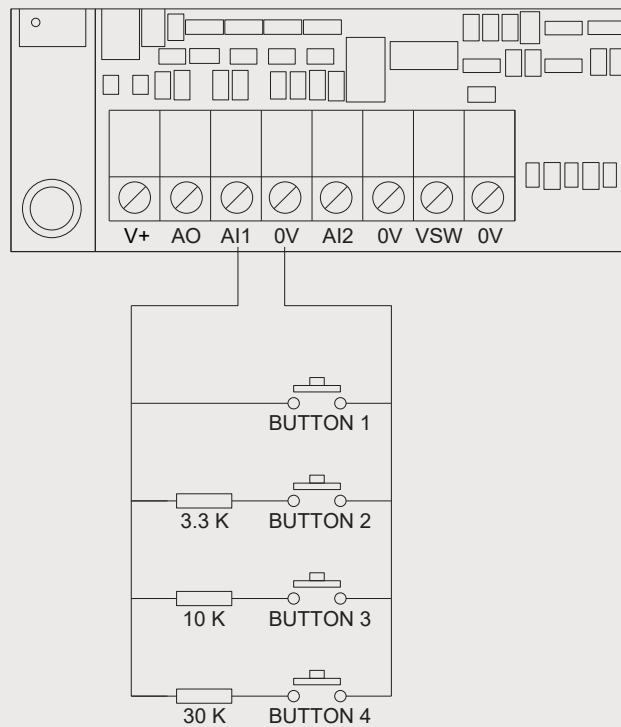

The input level is processed, and categorised as one of five levels.

Operation	Resistance	Analog Input	Level
Button 1	Zero ohms	~ 0%	Short Cut
Button 2	3.3 k $\Omega$	~ 25%	Low
Button 3	10 k $\Omega$	~ 50%	Mid
Button 4	30 k $\Omega$	~ 75%	High
Nothing Pressed	-	100%	Open Cct

Inputs can be mapped for use as a Day-to-Day open/close/auto switches or any other digital function.

In the example above, pressing more than one button simultaneously will give a lower signal, but will still be categorised as the lower button.

## 5. Fault Codes

**Note:** The fault flash codes at the coordinator and at the MCP are different, and have different meanings. Ensure that you are referring to the correct fault guide

### 5.1. Coordinator Flash Codes

Flashes	Fault	Action
1	Service Due	The service interval is due. The service interval warning may be cleared by a Level 2 Reset Key, or parameter reset by Sceptre.
2	Comms Fault	An OS3 communications link is broken, and the system cannot communicate with some devices. Check LEDs on all MCPs. Lamp test all MCPs. Check wiring. Replace MCP if faulty.
3	VA Fault	Check the incoming mains supply.
4	VB Fault	Check the connections to the battery. Check the battery voltage, if low, allow the battery to charge.  If necessary, replace the batteries.
5	Battery Fault	Check the battery voltage
6	Charger Fault	Check the connections to the battery. Check the battery voltage, if low, allow the battery to charge.  If necessary, replace the batteries.
7	MCP Fault	Check each MCP on this coordinator. Any MCPs showing flashing yellow LED should be investigated. See MCP fault codes below.
8	MCP Switches	MCPs have inconsistent switch settings - check all MCP top of stack and zone switches.
9	VB Loaded	An MCP is drawing current from the VB supply, preventing battery charging. Check the VA supply ~25.5 V. Disconnect the battery and look for non-functioning MCPs.
10	VB Fused Trip	The VB power line has drawn excessive current. Check wiring, and isolate VB to find fault.
11	Incompatible	MCPs and Coordinator have incompatible software – update software on coordinator or MCPs. Pressing the INST button (top centre of Coordinator PCB) can start the MCP update which takes approximately 2 minutes.
12	System Fault	The parameter set is corrupt or some other critical fault has occurred. Report to SEC Technical. Removing all power and restoring may cure the problem.
13	OSLink Fault	Multi – coordinator systems only.  The OS3 connection to other coordinators or repeater panels has a problem. Check all devices have a unique OSLink addresses [OADD], and other configuration parameters. Check OSLink wiring.
14	Remote coordinator faulty	Multi – coordinator systems only. Another coordinator (connected via OSLink) has a fault.

## 5.1. Coordinator Flash Codes (continued)

Flashes	Fault	Action
15	Comms Warning	Data communication around the loop is broken, but the system can still communicate with all devices. The two MCPs either side of the break should be flashing yellow.
16	Unused/Reserved	

**Note:** The coordinator will flash the front panel yellow LED to indicate the cause of the coordinator fault. If more than one fault is present, the fault codes are blinked out in sequence with a pause between each one.

## 5.2. MCP Flash Codes

If the green and yellow LED on the MCP are both constantly lit, then the system is indicating service due. This indication can only be reset by an engineer.

If the yellow LED on the MCP is constantly lit (i.e. not flashing) then the fault is elsewhere on the system.

The MCP will constantly flash the front panel yellow led to indicate a local fault. To discover the fault code, the silence button (MCP underside, left hand side) must be briefly depressed, and the number of yellow flashes counted. If more than one fault is present, the fault codes are blinked out in sequence with a pause between each one.

Flashes	Fault	Action
1	Service Interval Due.	Service interval due.
2	Smoke Detector Open Circuit	Check wiring to the smoke detector and presence of the end of line terminating resistor.
3	VA Fault	Check the incoming mains supply at the coordinator.
4	Motor Open Circuit	Check the connections to the actuator, and presence of the end of line terminating resistor.
5	Motor Short Circuit	Very high current drawn by actuator. Check the wiring for short circuits. If possible, test the actuator from a separate supply, otherwise replace the actuator.
6	Motor Current	Excessive current drawn by actuator. Check the vent is not mechanically obstructed. If possible, test the actuator from a separate supply, otherwise replace the actuator.
7	Motor Limit Switch	The vent motor position has not been proved open or close. Press the reset button until the vent is closed.
8	Smoke Detector Short	The smoke detector input is taking excessive current. Check smoke detector wiring for short circuits.
9	Comms Fault	This MCP is receiving bad data. Check wiring. Check no MCP jumper on connection board. If system wide, check coordinator.
10	Comms Timeout	This MCP is receiving no data. Check wiring. Check no MCP jumper on connection board. If system wide, check coordinator.

## 5.2. MCP Flash Codes (continued)

Flashes	Fault	Action
11	VA Fault	An OS3 communications link is broken, but the system can still communicate with all devices. The two MCPs either side of the break should be flashing yellow.
12	VB Fault	This MCP has lost its VB power supply.
13	Active Overdue	<p><b>Note:</b> indication of this fault is delayed for an hour to allow use of the system in a fire without raising fault conditions.</p> <p>The vent has been closed, but the smoke detector input is not clear. Clear any smoke or reset the fire alarm, then press reset to clear the smoke detector. If faulty, replace the smoke detector head.</p> <p>Also top of stack or stairwell was manually closed while the smoke stack remains active. Close all smoke stack vents.</p>
14	Magcatch Dropout	<p>Mains power was lost, and the battery voltage dropped too low to support the magnetic catches.</p> <p>Restore the mains supply and reset the vents.</p>
15	Coordinator Fault	Check fault indication at the coordinator – Refer to coordinator flash codes in Section 4.1.
16	Unused/Reserved	
17	User Defined Fault 1	Programmable fault.
18	Do Not Use	
19	Three Wire MCP Fault	Communications fault with 3 wire device
20	PSW Overload	Excessive current drawn on PSW output.



Creating a healthier & safer environment

Lancaster House  
Wellington Crescent  
Fradley Park, Lichfield  
Staffordshire WS13 8RZ

**+44 (0)1543 443060**  
**sales@secontrols.com**  
**www.secontrols.com**

