

# VARIABLE SPEED FAN CONTROL PANEL 3 kW - 11 kW

Technical information and operating instructions



## Introduction:

The SE Controls Variable Speed Fan Control Panel is a fixed modular design that is built and tested to provide a method of operating a single 400 V three phase 50Hz duty / standby fan arrangement.

It must not be used for any other application or in conjunction with other manufacturers' products without prior consultation with SE Controls.

Installation of this equipment must only be carried out by competent and qualified persons.

This information pack must be retained for future reference by the client and be made available for reference by persons installing, or servicing the panel.

## Application:

The Variable Speed Fan Control Panel is a control system designed to operate 400 V/ 3PH/50 Hz fans in a duty and standby configuration for smoke control in a powered extract system.

The control of environmental fans is also possible when specific additional packs are fitted.

Operating from a 400 Volt supply, the Variable Speed Fan Control Panel can control fans from 3kW - 11 kW (Standard Versions).

# Contents

<b>1. General Information</b>			<b>3. Connections, Continued</b>	
1.1. General Safety Information	4		3.17. Variable Speed Fan Panel Connections	17
1.2. Health and Safety	4		3.18. Activation Contacts	18
1.3. Environment	4		3.19. FOS Switch - Boost	19
1.4. User Responsibilities	4		3.20. OSLink Network	19
1.5. Maintenance	5		3.21. Outside Air Temperature Hot Corridor Solution	20
1.6. Installation and Connection	5		3.22. 0-10 NV Fan	20
1.7. Fault Finding	5		3.23. Test Switch	21
1.8. Contact Information	5		3.24. Battery Connections	21
<b>2. Specification</b>			<b>4. System Design</b>	
2.1. Device Overview	6		4.1. System Design	22
2.2. External Indication	6		4.2. Design Checklist for each VS Fan Panel	22
2.3. Fuses	7		<b>5. Installation, Commissioning and Fault Finding</b>	
2.4. Miniature Circuit Breakers	7		5.1. Fixing	23
2.5. Recommended Cable Types	8		5.2. First power Up Tests	24
2.6. Cable Distances and Sizes Disclaimer Information	8		5.3. Inverter First Time Set Up and Parameters	25
2.7. Volt free Indication	8		5.4. Basic Fault Finding for Standard Version	26
<b>3. Connections</b>			<b>6. Circuit Diagrams</b>	
3.1. Connections	9		6.1. Circuit Diagrams	27-31
3.2. Three Phase Power In Connection	9		Variable Speed Fan Control Panel 3kW-11kW	
3.3. Duty Fan and Stand By Fan Connections	10			
3.4. 400 Vac Fan Connection	10			
3.5. 230 Vac Fan Connection	11			
3.6. System Active	11			
3.7. System Healthy (VFC)	12			
3.8. Lifts to Ground	12			
3.9. 230 Vac Smoke Damper	13			
3.10. Generator Signal	13			
3.11. Environmental Radial Damper	14			
3.12. CloudLink Connection	14			
3.13. Generator Status	15			
3.14. Pressure Sensors	15			
3.15. 24 Vdc Smoke Dampers 1	16			
3.16. 24 Vdc Smoke Dampers 2	16			

## Important Notices

- Do NOT allow abuse or mishandling of the device.
- Do NOT adjust or alter the device or its enclosure including labelling/markings.
- Do NOT use this controller for any other purpose other than that intended by the manufacturer.
- Do NOT allow installation of this equipment by persons not electrically qualified.
- Damage to the equipment due to failure to test the electrical integrity of external wiring will invalidate any warranties.
- Failure to install the device in accordance with the manufacturer's instructions will invalidate any warranties.
- Failure to follow current electrical regulations governing the installation of fixed equipment can lead to prosecution and may invalidate any warranties.
- Where a replacement is needed for consumable items e.g. fuses, they must be replaced with parts of equivalent manufacturing standard, compliance and rating.

**SE Controls accepts no liability for failure to comply with these statements or the installation and operation guidance in the following sections of this guide and reserves the right to invalidate the warranty of the controller**

**SE Controls reserves the right to introduce any modifications and improvements to the contents of this publication without the obligation of giving prior notice.**

# 1. General Information

## 1.1. General Safety Information



Read and observe the information contained in these instructions.

Please keep these safety instructions for future reference and maintenance. Reliable operation and the prevention of damage and risks are only assured if the equipment is assembled carefully and the settings are carried out according to these instructions and to the operating instructions of the drives.

Please observe the exact terminal assignment, the minimum and maximum power ratings (see technical data) and the installation instructions.

## 1.2. Health and Safety



**Electrical Safety:** Warning 230 Vac or 400 Vac mains supply can cause death, serious injury or considerable material damage.

**Competence:** This equipment is designed for professional installation only by qualified, trained and safety conscious electricians or skilled and trained staff with considerable knowledge of electrical equipment installation. These instructions must be followed and retained for future reference.

**Application:** this equipment is designed exclusively for the purposes of controlling automatically smoke and natural ventilation equipment.



**Personal Protective Equipment:** It is recommended that suitable PPE is worn at all times during the installation and connection of products in accordance with a recommended safe system of work.



**Handling and storage:** This equipment is heavy. Care must be taken in transportation to the installation location and during fitting. The equipment must not be dropped, impacted, allowed to get wet or abused in any other way.

The panel should be kept in an upright position at all times and should not be stacked more than one high during shipping or storage.

Mishandling can result in serious damage to the housing and the components therein.



**Risk of crushing:** this equipment can automatically close windows and other appliances without warning. Risk of serious injury from crushing of hands or fingers.

## 1.3. Environment



Redundant electronic products are classified as hazardous waste under the WEEE regulations (Waste Electrical and Electronic Equipment). Electronic parts must be disposed of by an authorised and licensed recycler. They must not be disposed of in household waste or 'general waste' skips.

If recycling facilities are not locally available, contact SE Controls who can arrange for recycling and disposal of old electronic products.

## 1.4. User Responsibilities

**United Kingdom Only:** BS 7346-8:2013 is a British Standard code of practice for the planning, design, installation, commissioning and maintenance of smoke control systems. Section 9 of the standard (Maintenance and Servicing) states that frequent inspection of the system should be undertaken by a named suitably-trained member of the premises management team.

Routine inspection of the system should be carried out in accordance with BS 9999:2008, Annex V.

### **For countries outside the United Kingdom:**

Please check with the local fire authority in your area regarding smoke control legislation, different user responsibilities may apply.

**Smoke control equipment should only be maintained by a competent person with specialist knowledge of smoke control systems and sufficient information regarding the system.**

## 1.5. Maintenance



A smoke control system should be checked and serviced periodically in accordance to local smoke control legislation.

Smoke control systems have to be serviced and checked for defects at least once per year by an authorised, trained and competent person.

**Within the UK a suitable service contract with SE Controls is recommended for this purpose.**

**The system must be protected against unintentional start-up!**

**All batteries need to be checked to see if they are within specification and in good condition at least once a year and replaced at least every THREE YEARS (please observe the battery commissioning label).**

**It is recommended regular checks of the inlet and exhaust filters of the panel, and they should be replaced at least once a year (2x FYS15070022)**

After maintenance, modification or repair the system must be functionally retested.

Compatibility; this equipment should only be used to operate with motors and other products approved by SE Controls. No liability will be accepted and neither guarantee nor service is provided if unapproved products are used in conjunction with this equipment.

## 1.6. Installation and Connection



Installation should be carried out by an authorised, trained and competent electrician.

Ensure correct cable type is used throughout the installation. All low voltage cables are to be routed separately from mains voltage cables and other electrically noisy cables. Flexible cables must not be plastered over and freely suspended cables must be provided with strain relief. Cables must be installed in such a way that they cannot be sheared, twisted, pierced or otherwise damaged during installation or use. Junction boxes should be accessible for inspection and maintenance.

**Do not attempt to install or alter the installation of the panel whilst connected to the power supply.**

## 1.7. Fault Finding



In the unlikely event that a problem occurs with the control panel, users are urged to contact SE Controls for assistance.

There are no user repairable parts. Fault rectification must only be carried out by authorised and competent persons.

## 1.8. Contact Information

**For sales, technical support and maintenance please contact:**

SE Controls  
Lancaster House  
Wellington Crescent  
Fradley Park  
Lichfield  
Staffordshire  
WS13 8RZ

**Tel:** 01543 443060

**Fax:** 01543 443070

**Website:** [www.secontrols.com](http://www.secontrols.com)

## 2. Specification

### 2.1. Device Overview

<b>Part number</b>	<b>3-11 kW Fan Control Panel</b> FCS041XXXX
<b>Dimensions</b>	1400 x 1200 x 400mm (H x W x D) – Standard Versions
<b>Mass Approx.</b>	140 - 210kg Dependant on options fitted
<b>Supply</b>	400 Vac 50/60 Hz
<b>Output</b>	Up to 5.9 A : 3 kW Version Up to 7.9 A : 4 kW Version Up to 10.7 A : 5.5 kW Version Up to 14.4 A : 7.5 kW Version Up to 21.3 A : 11 kW Version
<b>Battery Backup</b>	2 x 12V dc 12.0Ah sealed lead-acid (batteries not included)*
<b>Expected Battery Life</b>	3 Years @ 25°C
<b>Real Time Clock Battery Life</b>	10 Years
<b>Cable Entries</b>	Cable entries are via up to 32 off 20 mm cable glands
<b>IP Rating</b>	IP55
<b>Humidity Range</b>	Maximum 90% Non-Condensing
<b>Storage</b>	-25°C to 60°C
<b>Operating Temp</b>	-5°C to 40°C
<b>Altitude</b>	Up to 1000 metres above sea level without de-rating (2000 metres max)
<b>Rated Short Circuit Capacity (Icn)</b>	10 kA

\* 2 x required.

### 2.2. External Indication

Lamp	Detail
<b>Standby</b>	Lit when panel is healthy
<b>Activated</b>	Lit when duty fans are running
<b>Fault</b>	Lit when the duty fan is faulty or an internal fault has occurred

### 2.3. Fuses

Fuse	Rating	Function
F01	T 3 A	Service Socket
F02	4 A	Without Pressure Sensors
	8 A	With Pressure Sensors
F03	3 A	Main PLC (K20)
F04	2 A	Main PLC (K20)
X31	T 1 A	230 Vac Fan Damper (If Fitted)
X33	T 1 A	230 Vac NV Radial Dampers (If Fitted)
X38/F01	T 1 A	ATS (If Fitted)
X39/F01	T 6.3 A	Pressure Sensors (If Fitted)
X40/F01	T1 A	24 Vdc Smoke Damper (If Fitted)
	T2 A	24Vdc Smoke Damper + 10A Power Supply G01 and G02 (If Fitted)
X41/F01	T1 A	24 Vdc Smoke Damper (If Fitted)
	T2 A	24Vdc Smoke Damper + 10A Power Supply G01 and G02 (If Fitted)
X58	T8 A	Battery
SO1	BS 88, A3, 35 A	Mains Switch Disconnecter

### 2.4. Miniature Circuit Breakers

MCB	Rating	Function
Q01	B 10 A, 2P, 10 kA	G01 (PSU1) + Cooling Fan + Heater
Q02	B 6 A, 2P, 10 kA	Service Socket + 230 Vac Smoke Damper
Q03	B 6 A, 2P, 10 kA	G02 (PSU2) + NV Radial Dampers
Q05	B 16A, 3P, 10 kA	T01 INPUT (Variable Frequency Drive 1)
Q06	B 16 A, 3P, 10 kA	T02 INPUT (Variable Frequency Drive 2)
Q09	B 10 A, 3P, 10 kA	T03 INPUT (Variable Frequency Drive 3 - IF 400 Vac Variable Speed Environmental Fan is fitted)
	C 16 A, 3P, 10 kA	Q11 INPUT (If 400 Vac 3 Phase Environmental Fan is fitted)
	C 16 A, 2P, 10 kA	Q11 INPUT (If 230 Vac 1 Phase Environmental Fan is fitted)

## 2.5. Recommended Cables Types

Cabling For	Minimum number of cores	Recommended Cable Type
Incoming Supply	4 + Earth	FP 600 or equivalent
Incoming Earth Cable	10 mm <sup>2</sup> minimum or equivalent to live cores when the live cores are thicker than 10 mm <sup>2</sup>	
Standby Fan	3 + Earth	FP 600 or equivalent
Network	2 + Earth	FP Plus

All cabling will be in accordance with relevant standards and regulations for electrical Installation such as BS7671.

## 2.6. Cable Size and Distances - Disclaimer Note

Incoming supply (Minimum distance between the power distributor feeder and the panel entrance to guarantee a 10 kA maximum prospective short-circuit current at the input terminals).

Cable Size	Distance
2.5 mm <sup>2</sup>	3 m
4 mm <sup>2</sup>	5 m
6 mm <sup>2</sup>	7.5 m
10 mm <sup>2</sup>	12.5 m
16 mm <sup>2</sup>	20 m
25 mm <sup>2</sup>	30 m
35 mm <sup>2</sup>	43 m
50 mm <sup>2</sup>	58 m

### Incoming Earth Cable

10 mm<sup>2</sup> minimum or equal to Live cores where the live cores are thicker than 10 mm<sup>2</sup>.

### Cable Connecting the Fan

The length of the cable between the panel and load (fan) should be as short as possible and the voltage drop shall not exceed 5%.

## 2.7. Volt Free Indication

Terminal	Description
X28	Healthy system
X29	Smoke Fan Activated
X30	Lift to Ground



### 3. Connections

#### 3.1. Connections

The 16 mm terminals (fan connections) have a cable capacity of 4-35 mm<sup>2</sup> stranded or solid.

All 4 mm terminals have a cable capacity of 2.5 mm<sup>2</sup> stranded or 4 mm<sup>2</sup> solid.

**Each terminal is identified with a unique reference. Please check the circuit diagram for details.**

The following sections are to be used for guidance only and are subject to change.

Strip the outer sheath of all cables back to the entry point of the enclosure. Ensure enough sheath is left to provide mechanical protection against cable movement over time.

Inner cable cores should be dressed under the edges of the terminals. This provides a neater and more ordered solution. Only strip inner cores sufficiently to make a good electromechanical contact with the terminal blocks.

#### 3.2 Three Phase Power in Connection

Ensure the supply is securely isolated before connecting.

The Earthing cable should be connected to W02 (Earthbar).

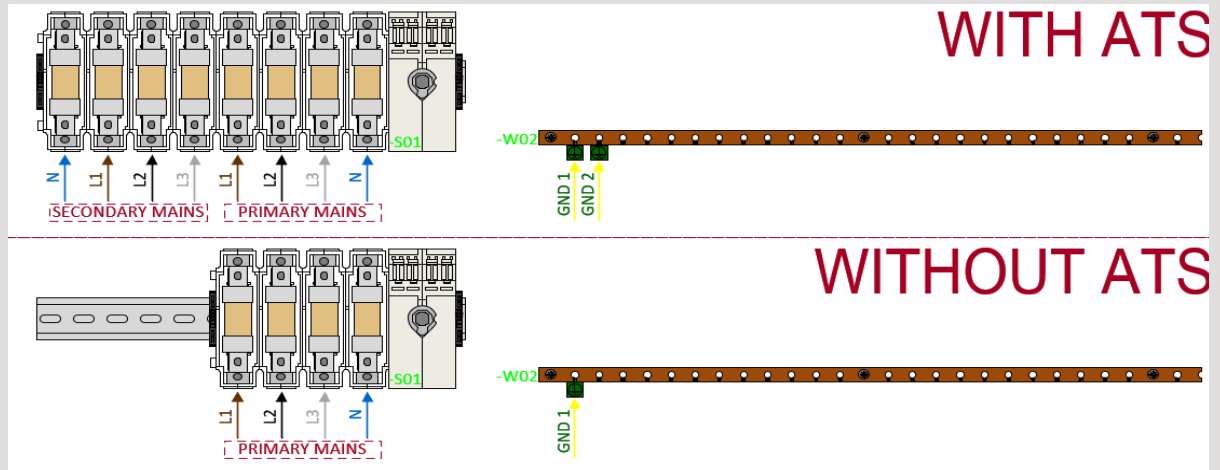

**Important:** The Mains Switch Disconnector will not isolate the circuits linked to connectors X28, X29, X30 and X32. These terminals are used to link the panel to external parts of the system. To isolate that part of the circuit, please check the devices to which they are linked. These terminals are connected to internal components via orange cables, which should help to identify which parts of the panel may remain energised even when the Mains Switch Disconnector is in its OFF position.

The incoming mains ferrite cores (**FYS15059026 x 2**) must be installed before the cables are connected to the switch disconnector. Insert one of the phase line conductors (exclude neutral and ground) through the toroid rings and then wrap it around the ferrite's twice. This operation needs to be executed for each phase line conductor L1, L2 and L3. Please refer to the illustration below for guidance.

This procedure also applies to the motor ferrite cores (**FYS15059027 x 3**) which should be added to each motor connection - three ferrite cores per motor.

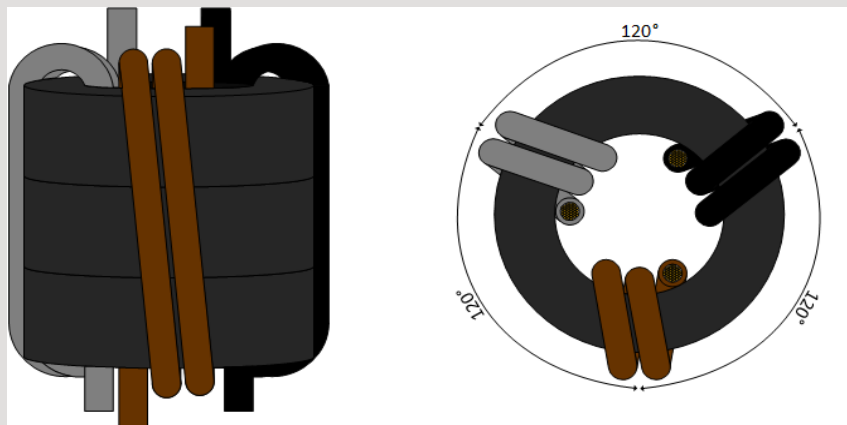

### 3.3. Duty Fan and Standby Fan Connections (X25 & X26)

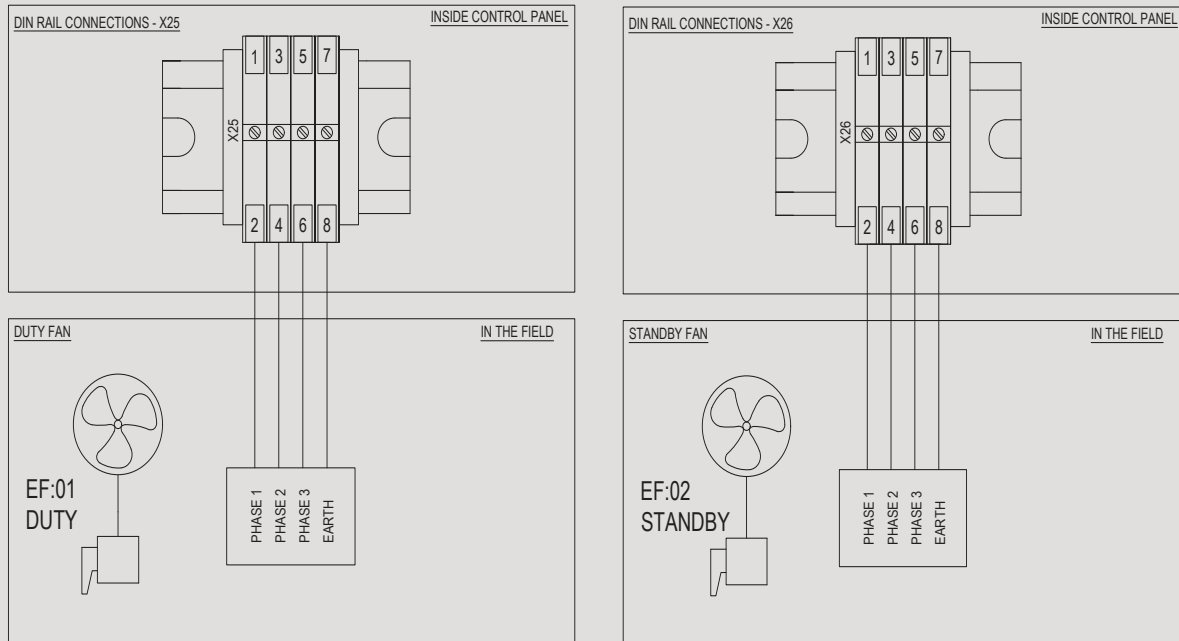

### 3.4. 400 Vac NV Fan Connections (X27, if this option pack is fitted)

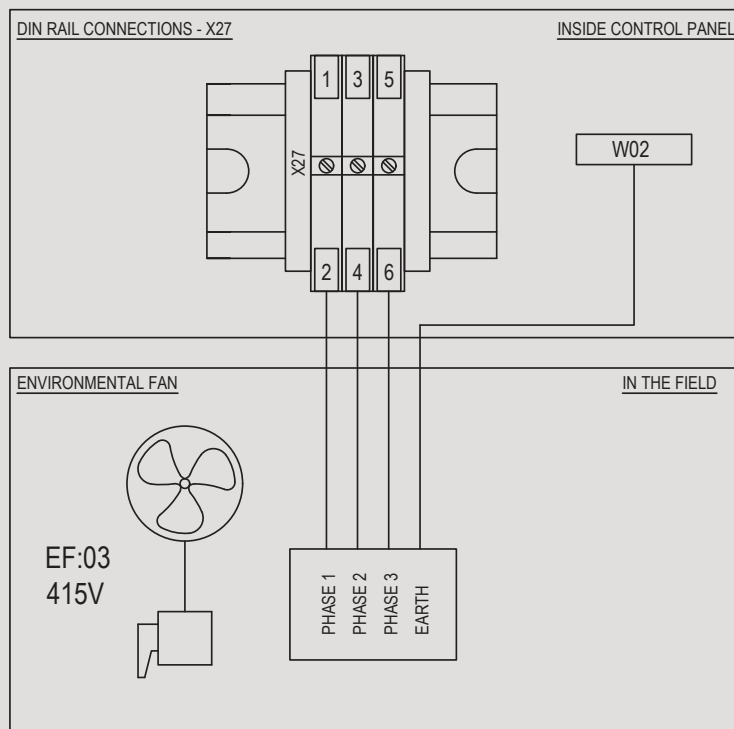

### 3.5. 230 Vac NV Fan Connections (X27, if this option pack is fitted)

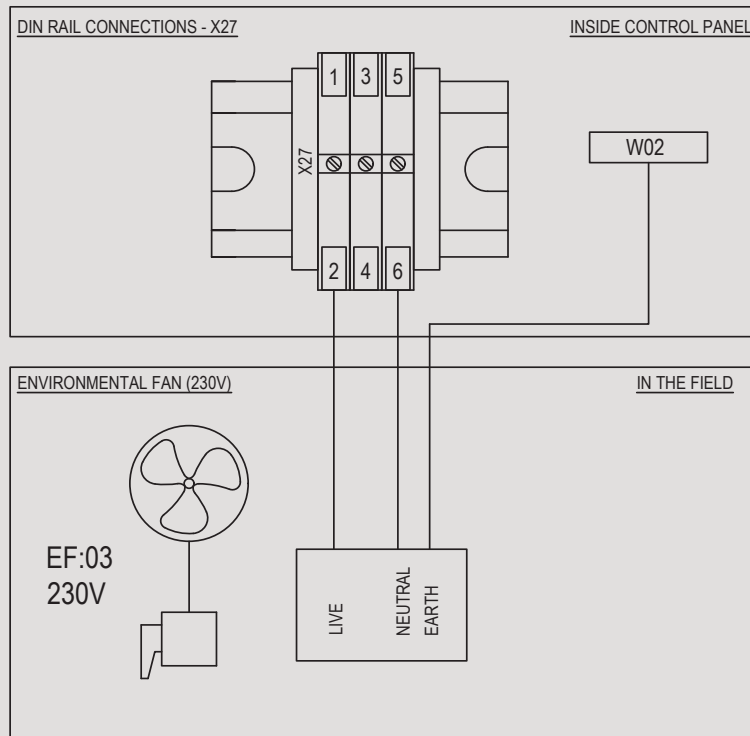

### 3.6. System Active (X28)

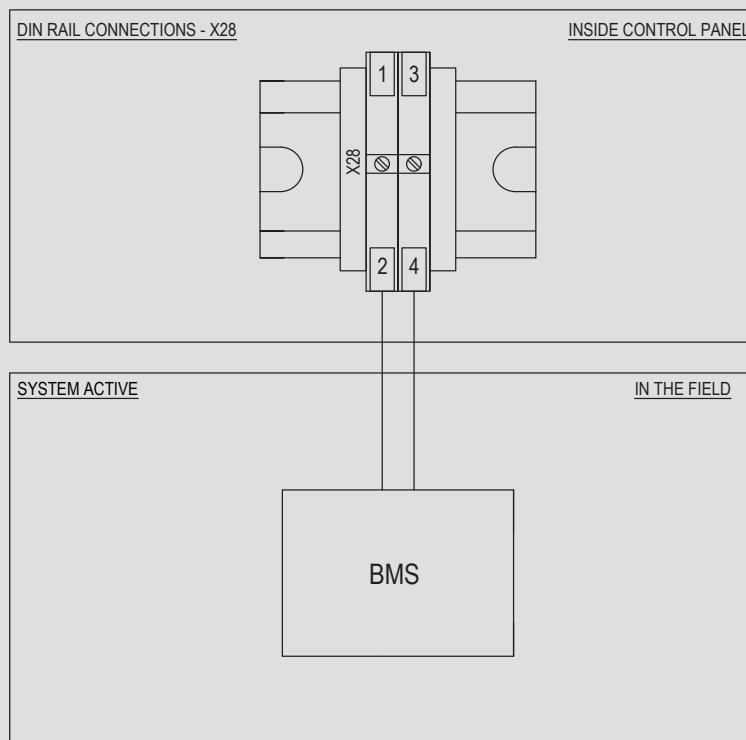

### 3.7. System Healthy (VFC) (X29)

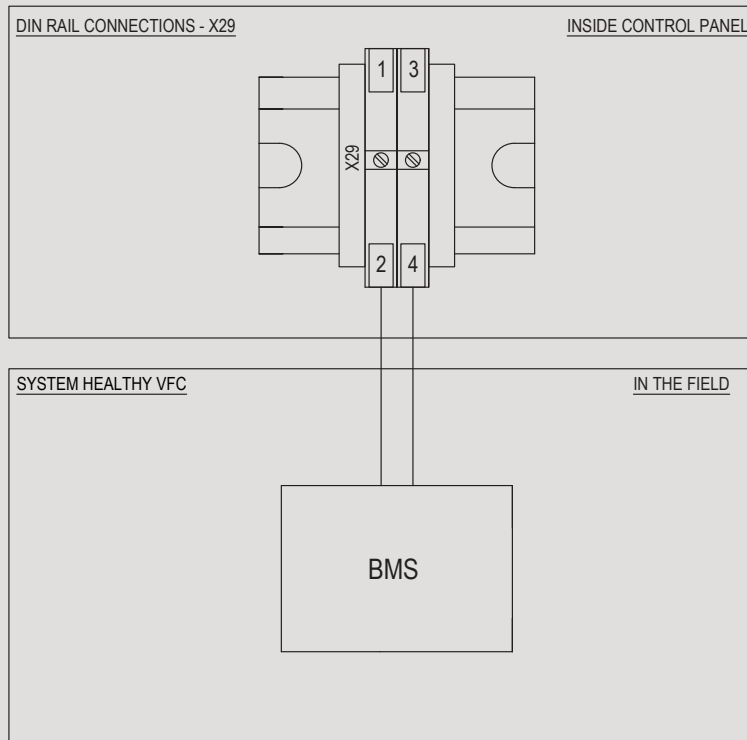

### 3.8. Lifts to Ground (X30)

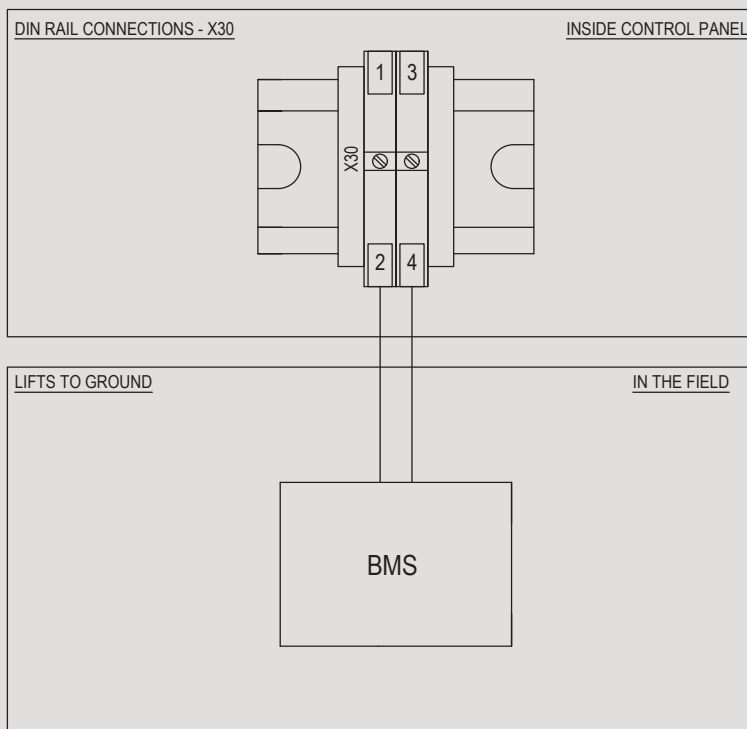

### 3.9. 230 Vac Smoke Damper (X31)

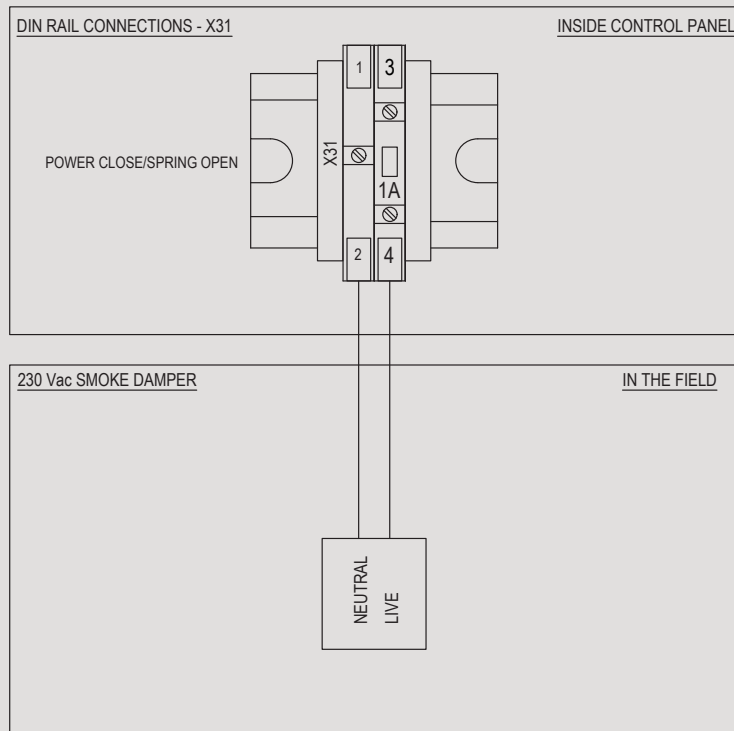

### 3.10. Generator Signal (X32)

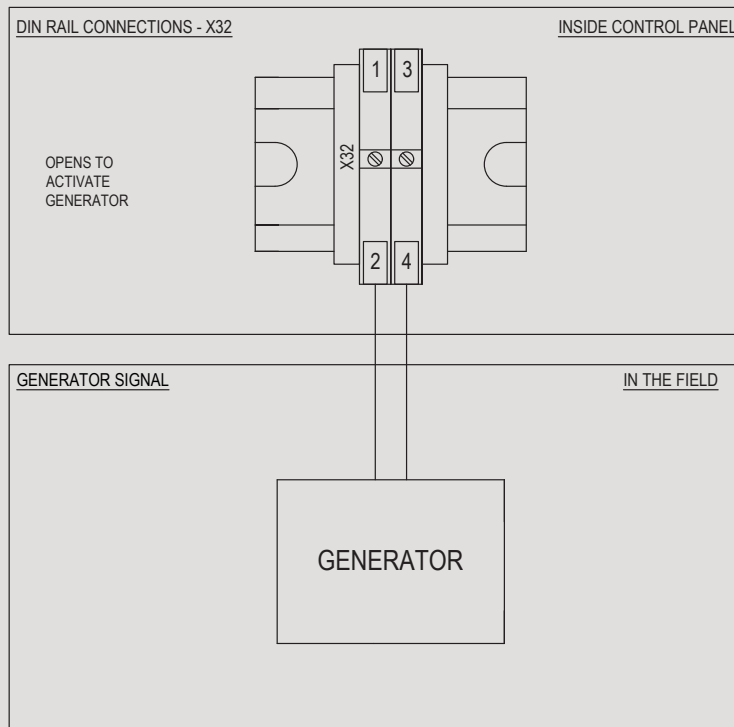

### 3.11. Environmental Radial Damper (X33, if this option pack is fitted)

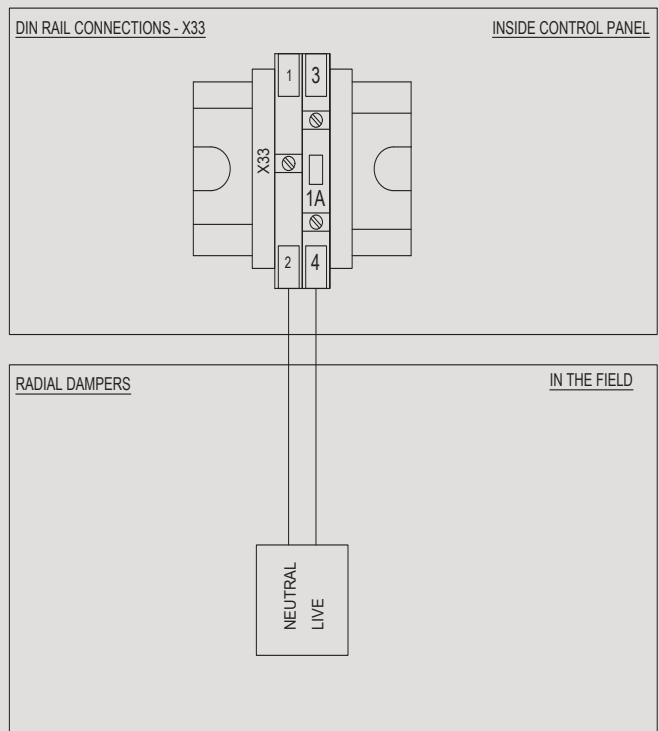

### 3.12. Cloudlink Connection (X36)

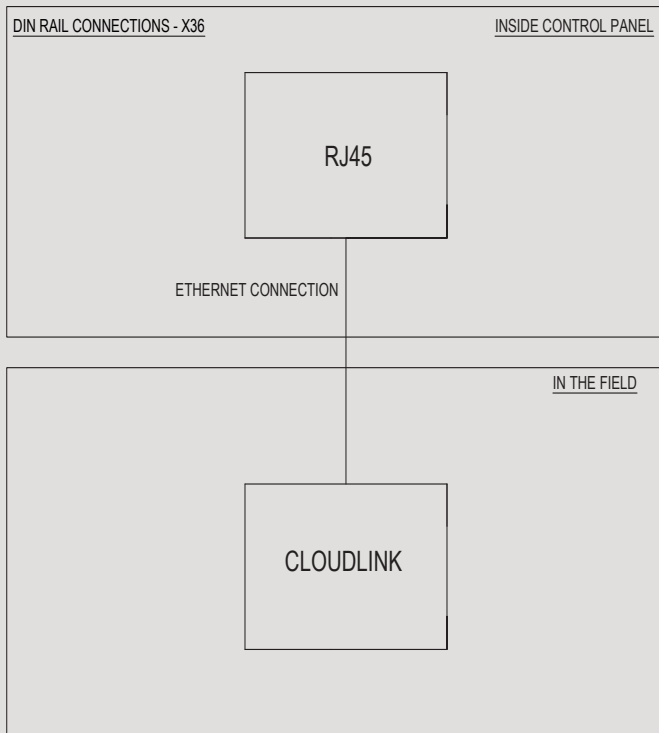

### 3.13. Generator Status (X38)

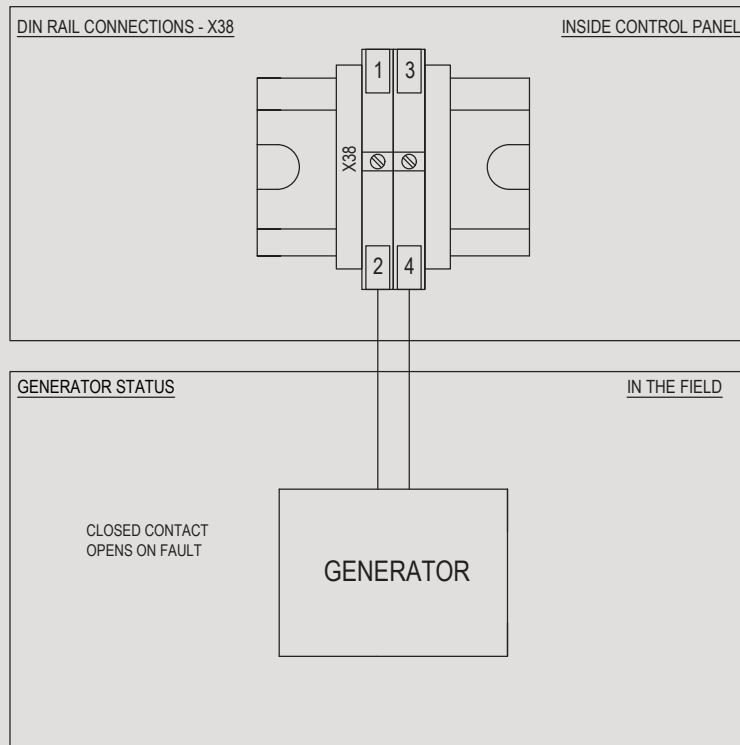

### 3.14. Pressure Sensors (X39)

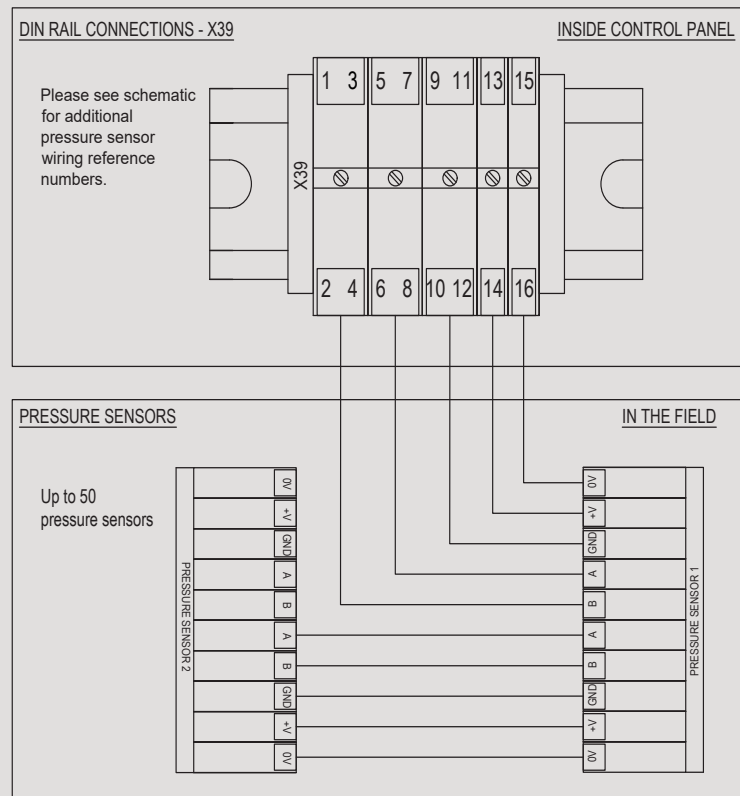

### 3.15. 24 Vdc Smoke Dampers 1 (X40)

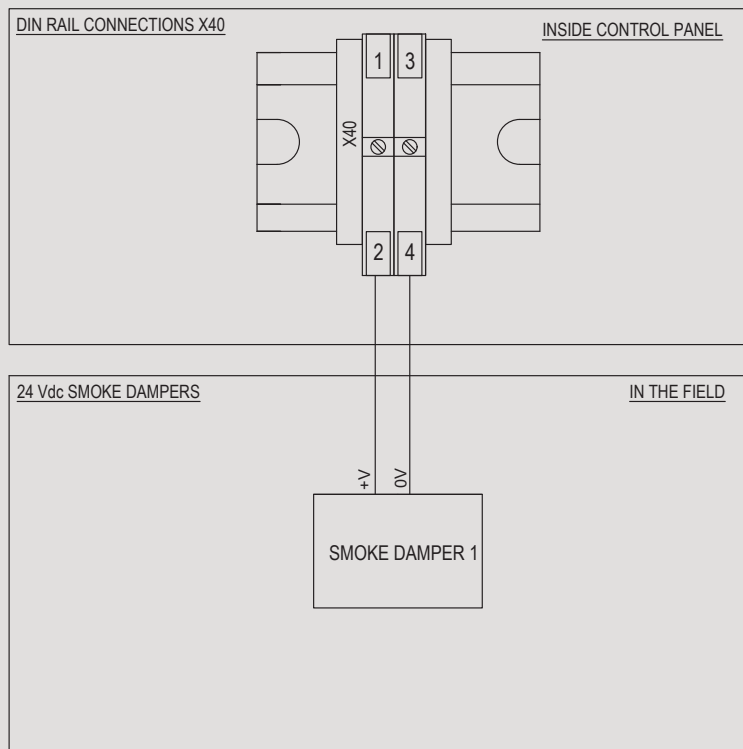

### 3.16. 24 Vdc Smoke Dampers 2 (X41)

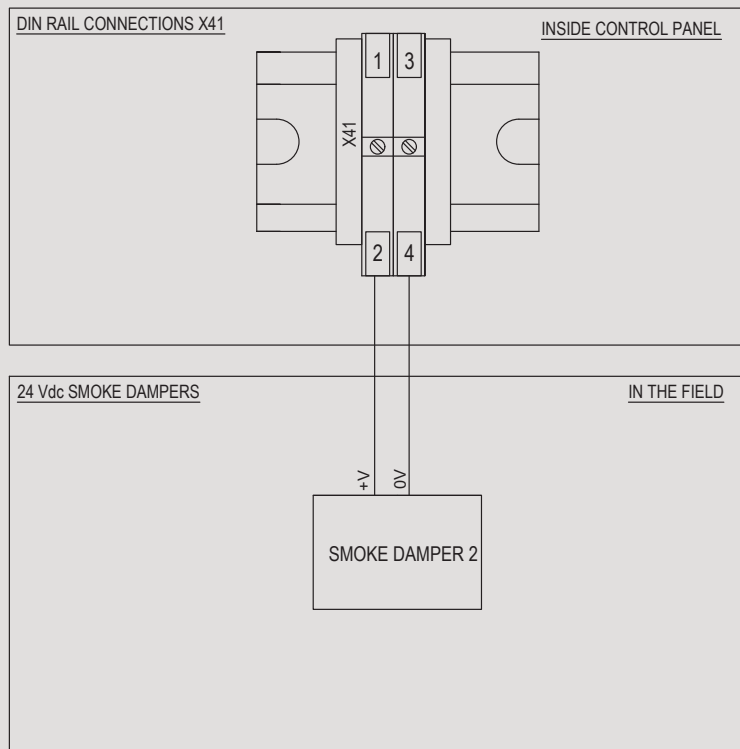



### 3.17. Variable Speed Fan Panel Network (X42)

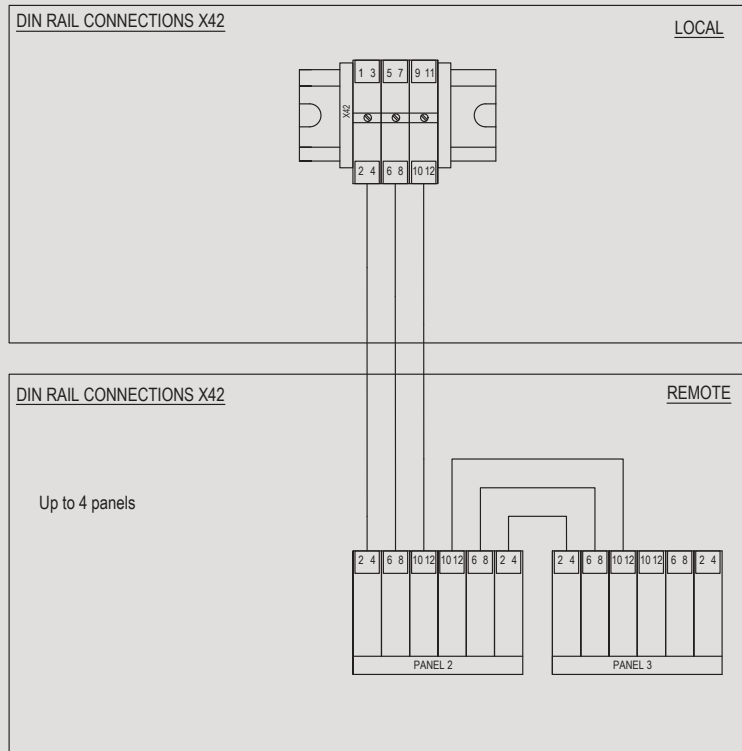

### 3.19. Activation Contacts (X43, X44, X45, X46)

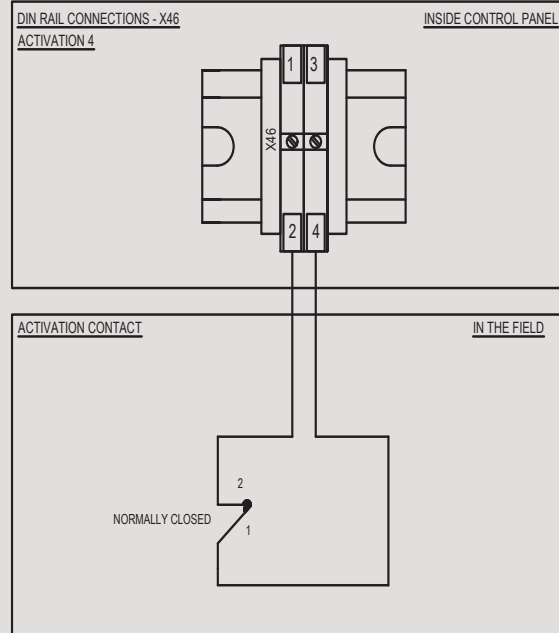
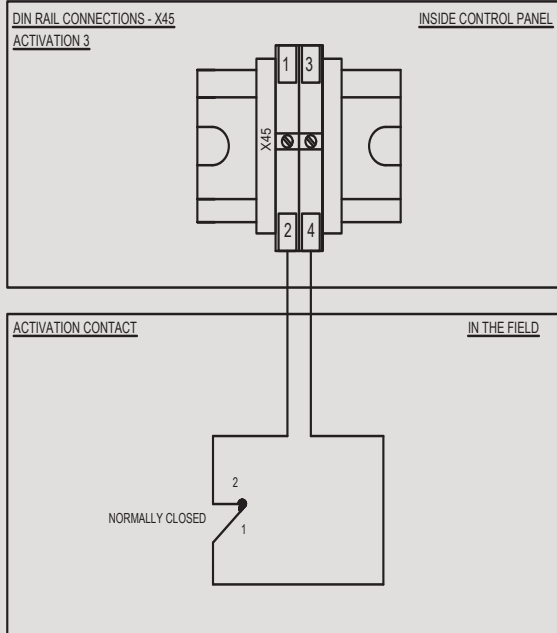
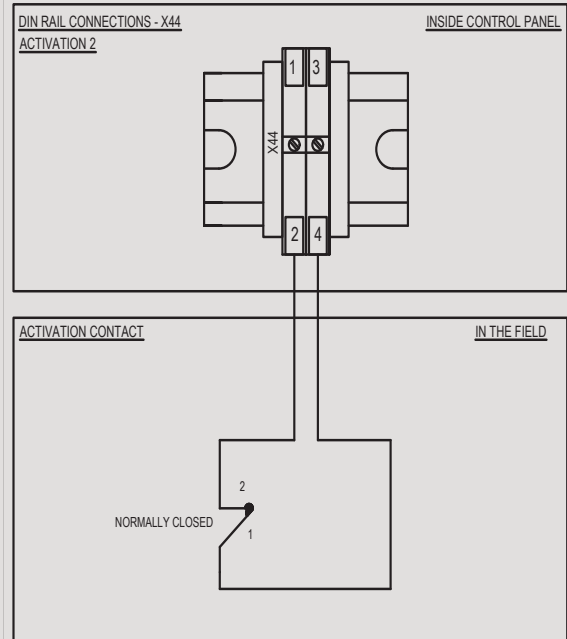
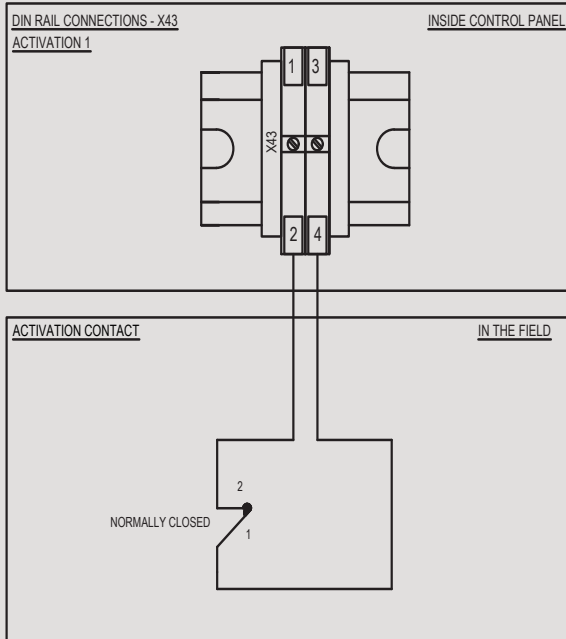



### 3.21. Outside Air Temperature Sensor Hot Corridor Solution (X49)

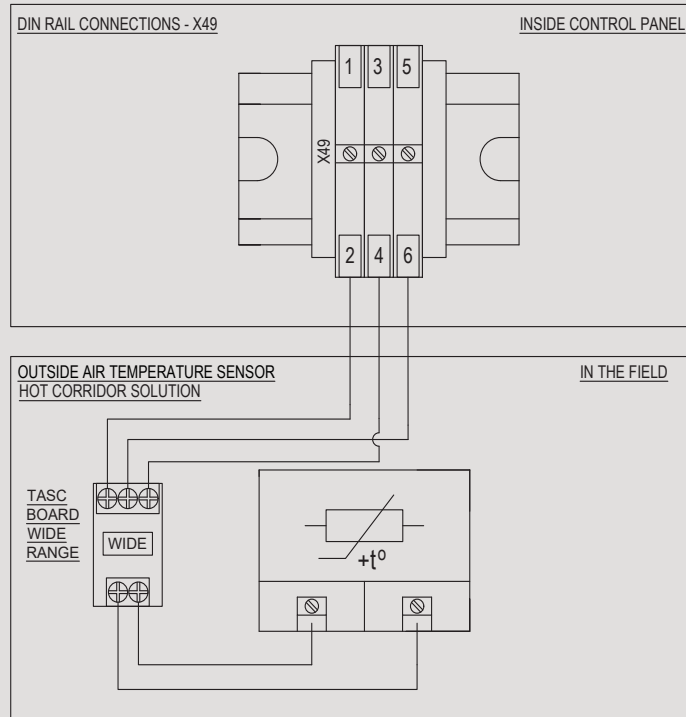

### 3.22. 0-10 NV Fan (X50)

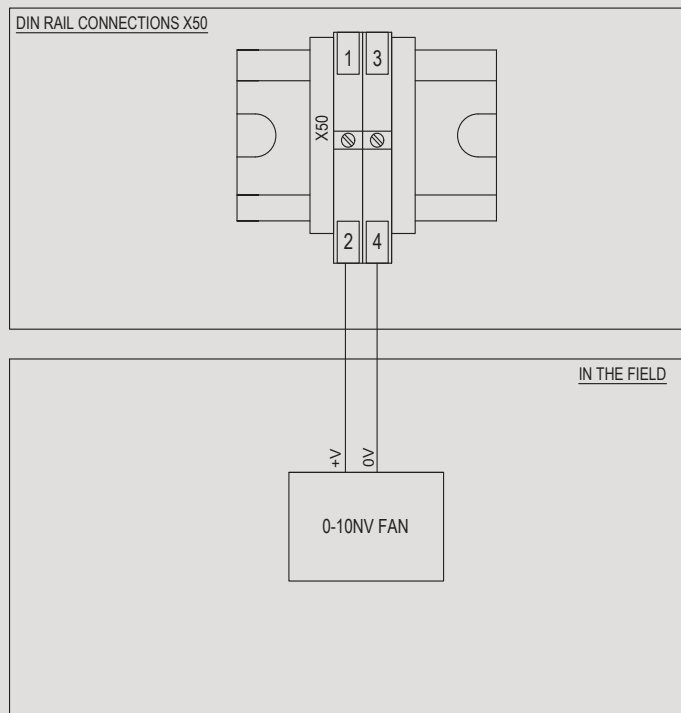

### 3.23. Test Switch (X51)

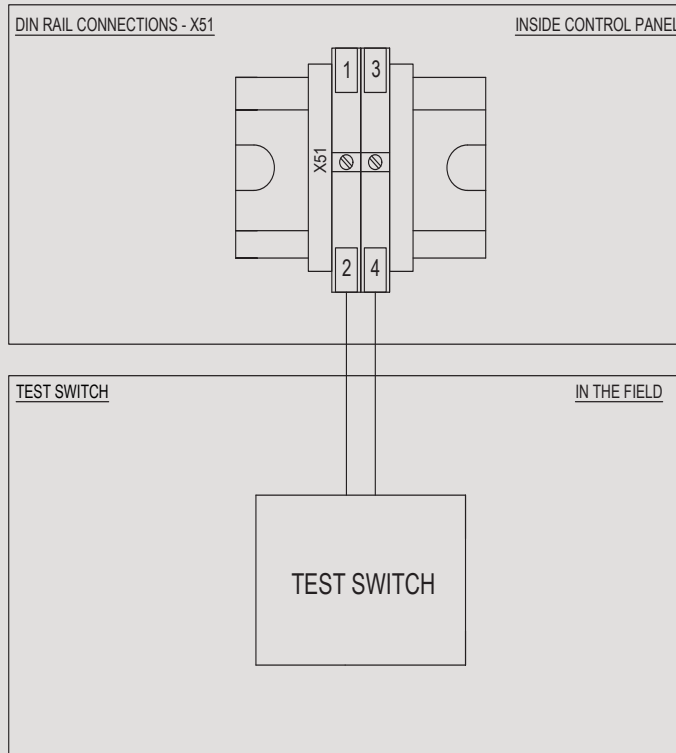

### 3.24. Battery Connections (X58)

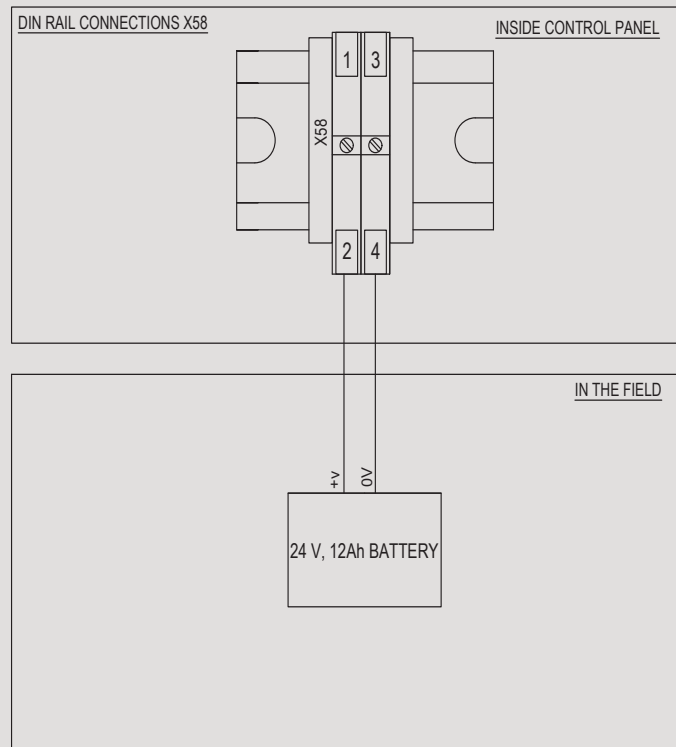

 **Battery Size:**  
2 x 12V/12Ah

## 4. System Design

### 4.1. System Design

Design of a smoke and heat control scheme is a technically complex task and needs to consider both national legal requirements and local fire/building regulations. This is beyond the scope of this document. If in doubt, consult SE Controls or approved agents who can give further guidance.

The system design documentation should include the 'Cause and Effect' list or similar to identify the essential smoke control functions of the system.

Before installation of any system, the following should be considered and documented where necessary.

### 4.2. Design checklist for each VS Fan Panel:

**Location:** Installation is in a clean, dry and secure location, accessible for maintenance.

**Location:** Not installed in sealed enclosure.

**Location:** Distance to the fans. Cable voltage drop is proportional to cable length, so locating the panel far from the load may require heavier gauge of cable. The addition of chokes may also be required when fans are located away from the panel.

**Electrical Load:** The Full Load Current (FLC) of the fan must be lower than the maximum continuous output current of the inverter.

**Electrical: Provision of Single** 400 V 3 Ph/50 Hz from external ATS unit or primary and secondary 400 V/ 3 Ph/50 Hz supplies into internally fitted ATS unit

## 5. Installation, Commissioning and Fault Finding

### 5.1. Fixing

When installing a panel internally, the fixing brackets should be screwed to the panel first. Then, hold the panel against the surface to which it is to be fixed. Mark through the holes. Drill appropriately sized pilot/fixing holes and use plastic plugs/cavity fixings where appropriate. Use appropriate bolts to secure the panel firmly.

When installing the panel externally, the fixing brackets may not be necessary as the panel is usually installed on a Metal Framing (uni-strut). Therefore, the panel can be screwed directly to the frame.

The minimum and maximum distance between the bottom of the panel and the serving level must be of 400 mm and 700 mm respectively. The recommended height of a uni-strut is 400 mm, in order to comply with previous limits.

- Installation of the panel in very warm locations (e.g. boiler rooms, hot plant rooms) should be avoided. The panel needs to be installed in a well ventilated space with room to fully open the doors.
- The panel must be firmly fixed to a solid surface. The panel can be mounted on any vertical surface such as a wall.
- The panel must be accessible for maintenance.
- Locating the panel a long distance from the load (fans) will increase cable voltage drops on long cables and may require use of more expensive cables with greater cross-section and even the addition of chokes.

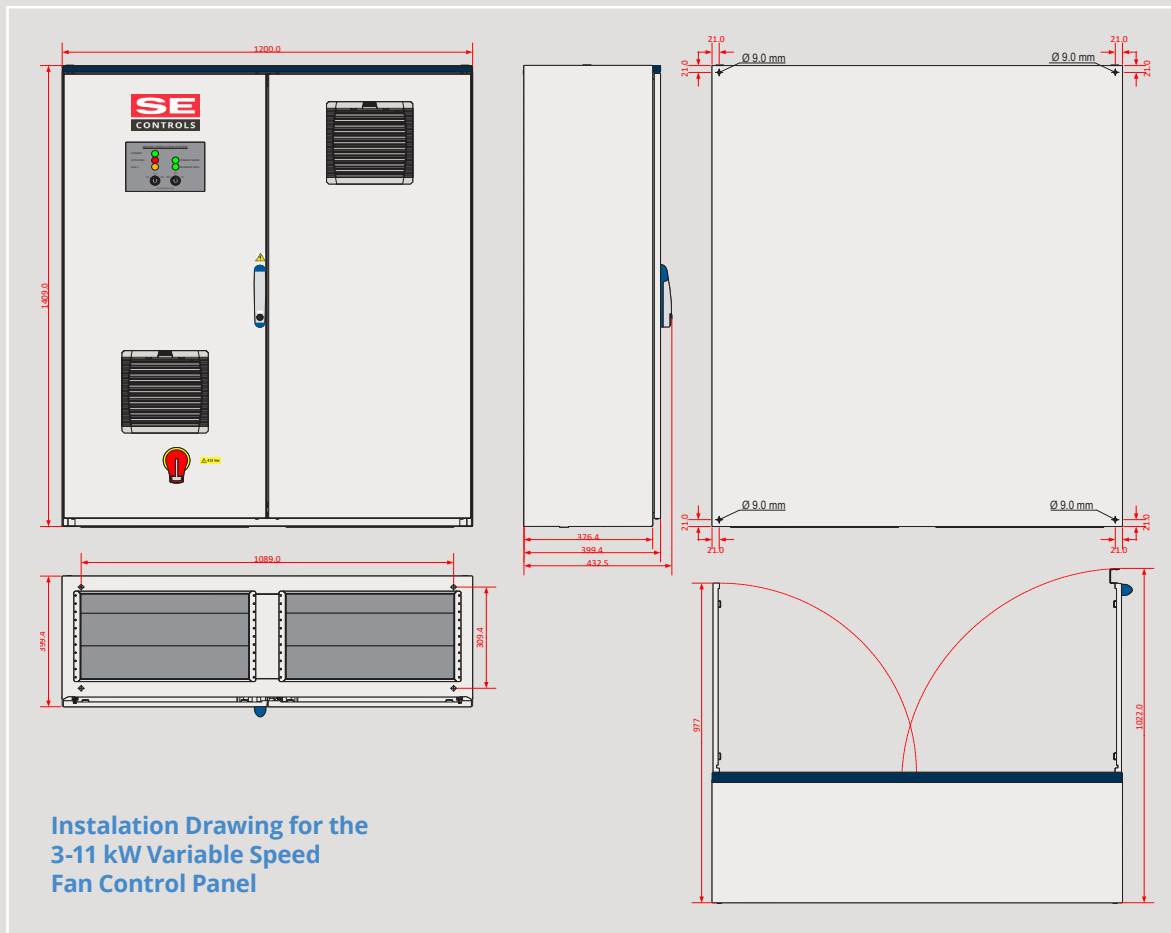

## 5.2. First power-up tests

Full commissioning of a new system requires the availability of three phase and neutral electrical supply. If activation is via a fire alarm controlled relay, ensure the fire alarm is normally closed when the system is healthy.

For networked systems, an unbound, faulty or disconnected OSlink card may cause a fault indication. For OSlink, check that the green status LED of the network is lit solid and if necessary re-initialise the network by pressing the button on the OSlink card to re-bind.

Where a 'Cause and Effect' (functional specification) is available, this will document a complete list of the required functions which must all be verified in turn. If this specification detail is not available, the commissioning engineer must ensure that each input is tested. This may require triggering of smoke detectors and simulating of fire alarm inputs.

If an ATS is fitted inside the panel, please check if the settings are as follows:

- The ATS should always be on AUTO MODE
- Transfer delay time Ts should be set to 10 s and Return delay time TBs should be set to 30 s.
- The dip switches are set correctly. Please see the table below:

DIP No.	Function	Setting			
1.2	Pole Setting	01	10	11	00
		2 poles	3 poles	4 Poles	Invalid setting
2.4	Mode Setting	01	10	11 (Default)	00
		No line priority	Manual back switching	Line priority LN1	Invalid setting
5.6	Voltage Setting	01	10	11	00
		240 VAC/419 VAC	230 VAC/400 VAC	230 VAC/380 VAC	Invalid setting
7	Frequency Setting	0	1 (Default)		
		60Hz	50 Hz		
8	Generator Setting	0	1 (Default)		
		No	Yes		
9	Generator stop delay setting	0	1 (Default)		
		240s	30s		

If the source of the secondary mains is a generator, please ensure that the generator is correctly set and it will be capable of supplying power to the panel within 15 s of the failure of the primary supply. This time is stated in accordance with BS 9999, BS EN 12101-10, BS 7346-8 and BS 8519.



### 5.3. Inverter First Time Set Up and Parameters

Below is a list of parameters that will be set during the production build and test.

These parameters are valid for the ACH580 range and Standard Versions only.

Parameter	Setting Required	Description
20.01	Embedded Fieldbus	Ext1 Commands
20.04	[3] DI2	Ext1 In2 source
20.21	[0] Request	Direction
20.41	[1] Not Used	Start interlock 1
21.3	Ramp	Stop Mode
28.11	EFB Ref 1	Ext 1 Frequency Ref 1
28.72	10.0s	Frequency Acceleration Time 1
28.73	10.0s	Frequency Deceleration Time 1
30.17	See Table Above	Maximum Current
37.02	[2] Motor Current %	ULC Supervision Signal
37.04	[2] Fault	ULC Underload Actions
37.16	000.0Hz	ULC Frequency Table Point 1
37.22	10.0%	ULC Underload Point 2
37.23	10.0%	ULC Underload Point 3
37.24	10.0%	ULC Underload Point 4
37.25	10.0%	ULC Underload Point 5
37.42	00005.0s	ULC Underload Timer
*58.1	Modbus RTU	Protocol Enable
*58.3	1 for T01, 2 for T02, 3 for T03	Node Address
*58.4	57.6 kbps	Baud Rate
*58.16	10.0s	Communicaion Loss Time
*58.25	DCU Profile	Control Profile
*58.107	1.6 [32]	Data I/07
*58.109	1.7 [32]	Data I/09

The Time and Date will also be set/checked as this will give an event log for any future faults or activations. This can be changed in the via the 'Primary Settings, clock, region, display, date and time'. Also ensure to select the Daylight Saving and set to EU.

Next is a list of parameters that need to be changed when testing the inverters with a motor drive. Typically, this is what will be changed by the engineer on site for the specific motor/fan it is commissioning the system with.

**\*If any of the marked parameters are changed the parameter 58.6 also needs to be changed to *Refresh settings (1)* to ensure the new values are saved.**

Parameter	Setting Required	Description
99.06	Info found on motor plate	Motor nominal current
99.09	Info found on motor plate	Motor nominal speed
99.10	Info found on motor plate	Motor nominal power
99.11	Info found on motor plate	Motor nominal cos $\Phi$

## 5.4. Basic Fault Finding for Standard Version

<b>No operation, No LEDs illuminated.</b>	Check if the isolator S01 is switched on.
	Check if all circuit breakers are toggled to the ON position.
	Measure the voltage between the terminal "a" (top) of X17 and terminal "a" (top) of X18, which should be 24 Vdc +/- 5 Vdc.
	Check the voltage in between the terminals of the Standby LED, which should be 24 Vdc +/- 5 Vdc.
<b>Duty Fan not running</b>	Check if the display of the T01 is lit.
	Check if the display of the T01 is showing a frequency higher than 0.00 Hz.
	Make sure that the First-Time setup of the T01 was carried out.
	Verify if at least one of the activation contacts is in an open status.
	Check the connections between X25 and the Duty Fan.
	Check if the Fireman's Override Switch (FOS) is not on OFF position.
<b>Standby Fan not running</b>	Check if the Duty fan is not running.
	Check if the display of the T02 is lit.
	Check if the display of the T02 is showing a frequency higher than 0.00 Hz.
	Make sure that the First-Time setup of the T02 was carried out.
	Check the connections between X26 and the Standby Fan.
	Check if the Fireman's Override Switch (FOS) is not on OFF position.
<b>Permanent Activation</b>	Check the connections between the fire alarm system and the activation contacts (X43, X44, X45, X46)..

### CAUTION



The Mains Switch Disconnecter will not isolate the circuits linked to connectors X28, X29, X30 and X32. These terminals are used to link the panel to external parts of the system. To isolate that part of the circuit, please check the devices to which they are linked.

These terminals are connected to internal components via orange cables, which should help to identify which parts of the panel may remain energised even when the Mains Switch Disconnecter is in its OFF position.

Wait for 5 minutes after disconnecting the input power before working on any of the Variable Frequency Drives (T01, T02, T03) or any of the parts and cables connected to those devices, since the voltage level may not be low enough!

# 6. Circuit Diagrams

## 6.1. Variable Speed Fan Control Panel 3kW-11kW

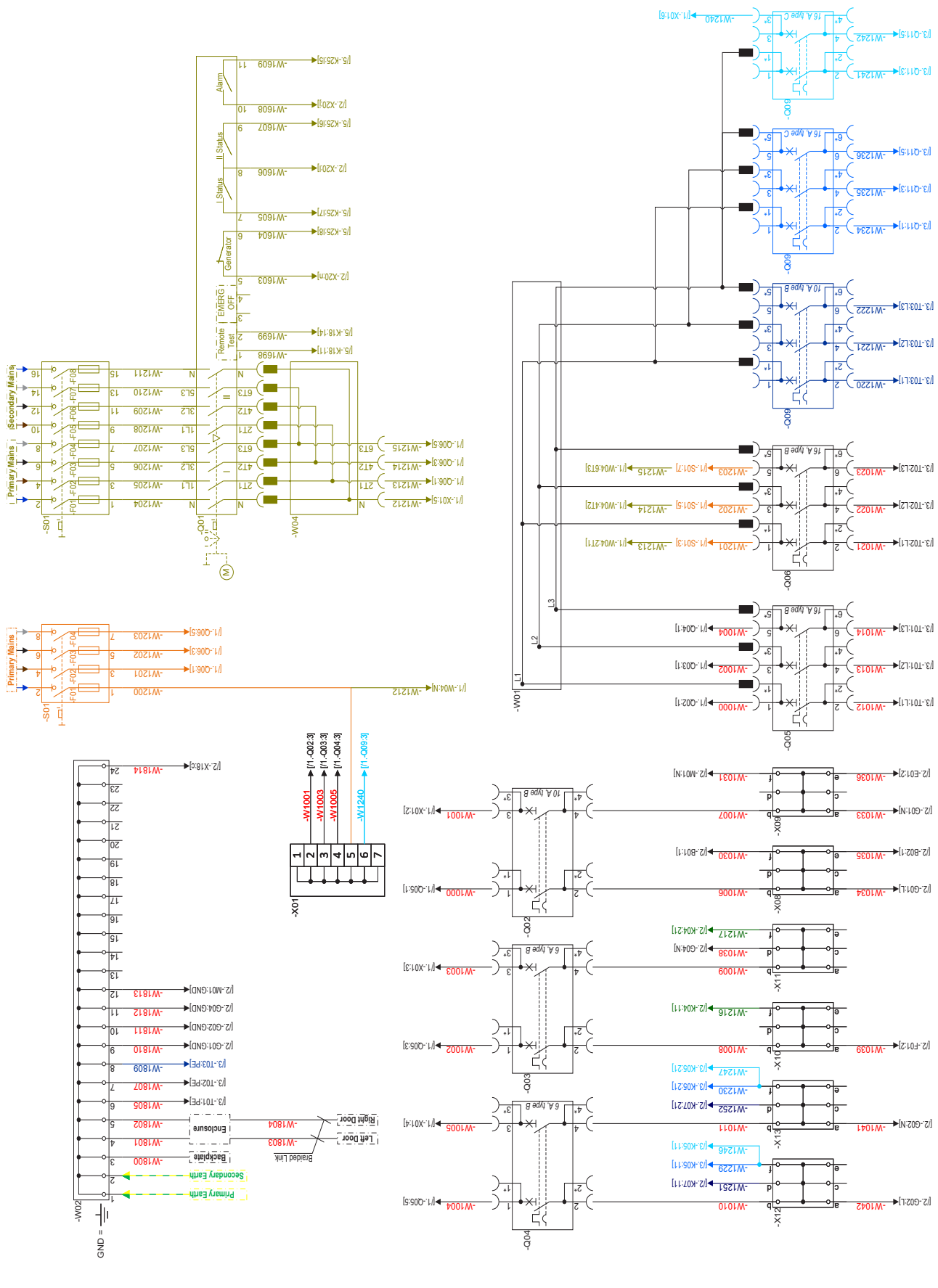

Please keep these operating instructions for future reference and maintenance.  
 Subject to technical modifications. Diagram is not binding.  
 For a larger version of this diagram, please contact: [technicalsupportteam@secontrols.com](mailto:technicalsupportteam@secontrols.com)

+44 (0)1543 443060  
[sales@secontrols.com](mailto:sales@secontrols.com)  
[www.secontrols.com](http://www.secontrols.com)





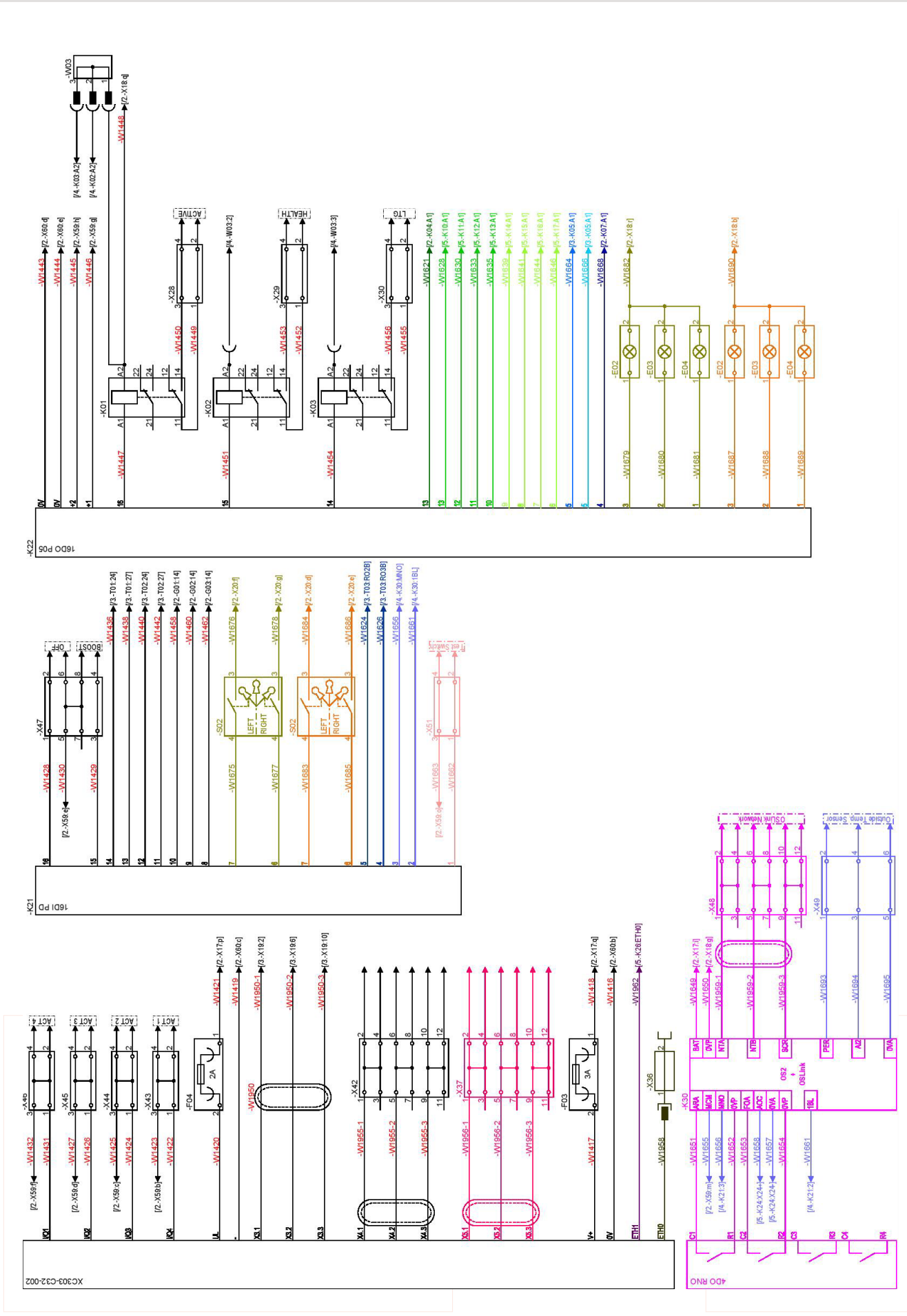

Please keep these operating instructions for future reference and maintenance.  
 Subject to technical modifications. Diagram is not binding.  
 For a larger version of this diagram, please contact: technicalsupportteam@secontrols.com





Creating a healthier & safer environment

Lancaster House  
Wellington Crescent  
Fradley Park, Lichfield  
Staffordshire WS13 8RZ  
United Kingdom

+44 (0)1543 443060  
[sales@secontrols.com](mailto:sales@secontrols.com)  
[www.secontrols.com](http://www.secontrols.com)

