

Twin SECO N 24 25

Chain Actuator

Technical information and operating instructions

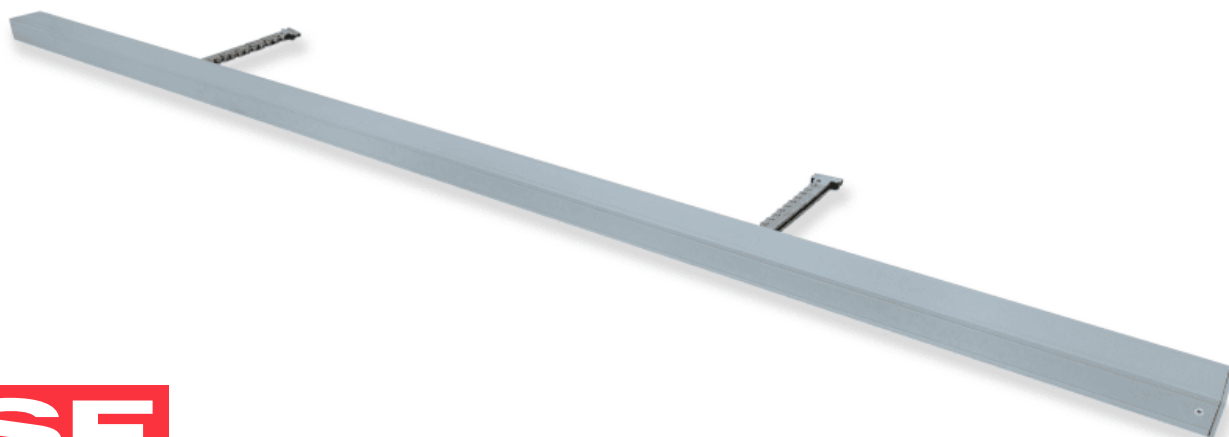

Chain Actuator / 24 V dc / 2 x 250 N

The Twin SECO N 24 25 is a compliant Chain Actuator designed to provide precise and reliable operation for Environmental Ventilation applications.

SE Controls manufacture this high-quality 'Made in Britain' actuator with the following features:

- Offers improved window performance and aesthetics for automated solutions
- 'Frequency of operation' data logging records every actuator movement
- Compact design with variable options for stroke length
- Standard finish is RAL 9006 (White Aluminum) but it can be customised to suit installation requirements
- Standard flex length is 2 m but this can be modified to suit installation requirements
- Standard range of pre selected quarter point bodies plus tailored lengths upon request.
- Extensive range of brackets to suit a variety of window systems
- Quiet operation with configurable speed control

Contents

1.0 General Information

1.1	General Safety Information	3
1.2	Health and Safety	3
1.2	Environmental	3
1.4	Application and Use	4
1.5	Installation	4
1.6	Maintenance	5

2.0 Specification

3.0 Installation Guide

3.1	Window Applications	7
3.2	Top Hung Window Installation	8
3.3	Bottom Hung Window Installation	8
3.4	Top Hung Window Installation	9
3.5	Setting the Zero Position of the Actuator	9

4.0 Technical Drawing

5.0 Connectivity and Wiring

5.1	Twin SECO Ni 24 40 to OS2	10
5.2	Twin SECO Ni 24 40 to NVLogIQ	11
5.3	Twin SECO NI 24 40 to 3A Transformer	11

1.0 General Information

1.1 General Safety Information

SE Controls reserves the right to introduce any modifications and improvements to the contents of this publication without the obligation of giving prior notice.

Read and observe the information contained in these safety instructions and respect the order of procedure stated therein.

Product reliability and risk prevention can only be achieved through careful assembly and proper settings following the operating instructions of this actuator..

Please observe the exact terminal assignment, the minimum and maximum power ratings (see technical data) and the installation instructions.

Please observe the exact terminal assignment, the



Danger!
General danger or precautionary warning with numerous implications.



Danger!
Danger that could cause personal injury. Danger of hands been crushed!



Warning!
Carefully read these warnings



Warning!
Draws attention to instructions that must be followed in order to prevent damage to the actuator.



Warning!
Danger of electric shock.



Notice
Indicates important notices to which attention must be paid.

1.2 Health and Safety



Electrical Safety; warning 230 V ac Dangerous voltage. Can cause death, serious injury or considerable material damage. Disconnect the equipment from the power supply at all poles before opening, assembling or carrying out any structural alterations.

Warning! Never connect the drives to 230 V! They are built for 24 V! Risk of death!



Personal Protective Equipment; It is recommended that suitable PPE is worn at all times during the installation and connection of actuator products in accordance with a recommended safe system of work.

Handling and storage; care must be taken in transportation to the installation location and during fitting. Actuator products must not be dropped, impacted, allowed to get wet or abused in any other way. Mishandling can result in serious damage.

Competence; installation and connection must only be carried out by authorised, competent and safety conscious persons.

1.3 Environmental



All actuator products contain metallic, plastic and electronic parts. Redundant electronic products are classified as hazardous waste under the WEEE regulations (Waste Electrical and Electronic Equipment). Electronic parts must be disposed of by an authorised and licensed recycler.

They must not be disposed of in 'general waste' skips.

Consult SE Controls for assistance.

1.4 Application and Use



When using the actuator, follow these safety instructions described herein. This equipment is designed for the automatic opening and closing of the stated types of windows.

For further applications, please contact SE Controls.

The actuator complies with current safety directives.

Operating safety can be guaranteed only if installers comply with the safety regulations in force in the country where the actuator is used.



Do not install two or more actuators on the same window without using a synchronisation accessory.



Any other application of the actuator must be approved after technical testing of the application. Use only original accessories or accessories approved by SE Controls to install the actuator.

The actuator is not a structural member of the window. Always mount the safety arms in bottom-hung applications. The position of the three-way switch button must be outside the field of action of the moving part of the window.

Do not allow children to play with the fixed or remote controls.



When opening or closing the window, make sure other people are far away from the moving part, even when a fire detection system is closing an open window.

It would be beyond the scope of these safety instructions to list all the valid regulations and guidelines.



Always make sure that your system corresponds to the valid regulations. Pay particular attention to: the aperture cross-section of the window, the opening time and opening speed, the temperature resistance of the cables and equipment, cross-sections of the cables in relation to the cable lengths and power consumption.



Care must be taken to ensure that actuator products are controlled with compatible products; refer to SE Controls. No liability will be accepted and no guarantee nor service is granted if actuator controls are used without such compatibility being confirmed.

1.5 Installation



Warning! Incorrect installation may render the actuator dangerous! Follow all the instructions set out below and all technical advice supplied by SE Controls.

Installation of this equipment must only be carried out by authorised, competent and safety conscious persons.



The actuator must be assembled and connected only by specialised staff who have been properly trained and who are familiar with the problems associated with automatic window opening and closing systems, technical reference standards and safety standards.



The window closes automatically. When opening and closing, the actuator is operated via a control system.



Take care - the open/close force is high enough to cause injury!



During assembly and operation do not obstruct the window opening!
Danger of crushing/trapping!

Routing of cables and electrical connections only to be done by a qualified electrician.



Power supply leads 230 V ac to be fused separately by the customer. Keep power supply leads sheathed until the mains terminal.



All low voltage cables (24 V dc) to be installed separately from high voltage cables. Flexible cables should not be plastered in. Provide strain relief for freely suspended cables.

The cables must be installed in such a way that they cannot be damaged.

Junction boxes must be accessible for maintenance work.



Adhere to the type of cables, cable lengths and cross-sections as stated in the technical information.

After installation and any changes to the system check all functions by a trial run.

1.6 Maintenance

Always disconnect the actuators supply voltage and batteries (if applicable) during cleaning or maintenance operations, especially if the actuator is equipped with an



The system must be protected against unintentional re-starting.

All smoke ventilation systems must be periodically (annually) checked, serviced, maintained and, if necessary, repaired and re-tested by a authorised, trained and competent, safety conscious person.

Maintenance shall be carried out in accordance with the requirements of;



- Building regulations 2002
- Health and Safety at Work Act 1974
- I.E.E Regulations
- Regulatory Reform (Fire Safety) Order 2005
- Building Safety Act 2022

In order to keep the equipment in optimum operating condition it is recommended that ventilation systems are similarly maintained.

There are no user repairable parts in this equipment.

Basic checks that can be carried out include;



- At least once a year, check that the power cable and connection has not been damaged and that it shows no sign of wear
- Check that no object obstructs the window movement.
- If faults arise, never work on the actuator and never attempt to disassemble it.
- If the actuator fails to function or is damaged, contact SE Controls.
- Do not use the actuator until it has been repaired or replaced.

A suitable service contract with SE Controls is recommended for this purpose.

The gear system is greased for life and is maintenance free.



Defective equipment must only be repaired by SE Controls. Only original spare parts are to be used.

After maintenance, repair or any changes to the system check all functions by a trial run.

2.0 Specification

Actuator	SECO N 24 25
Actuator Type	Twin Chain Actuator
Voltage (all ± 5%)	24 V dc
Amp Draw Current (with load)	1.0 A
Stroke	250 mm, 350 mm (configurable)
Operating Speed	5 mm/sec (configurable) 3 mm/sec (option single application only)
Ambient Operating Temp	-5°C to +60°C
IP Rating	IP20
Thrust Force	250 N x 2
Close Force	250 N x 2
Clamping Force	4000 N x 2
Soft Close	Yes
Switching	Electronic
Seal Relief	Programmable up to 20 mm
Synchronisation	Optional
Standard Finish Powder Coated	RAL 9006 (White Aluminium)
Colour Option	Other RAL colours available on request
Flex Length	2 m
Flex Type	2 core PVC 4 core (volt free contact) as option
Flex Colour	Grey
Duty Cycle	22% (approx. 2 mins on, 7 mins off)
Product Warranty	10,000 cycles or 12 months from the date of invoice ¹
Bracket	Sill fixing/ face fix/ thru body sill
Application	Environmental Ventilation

¹ Commercial terms for each project will supersede this warranty information.



Please ensure the controllers have a minimum 1 second delay between switching if you are not using SE Controls products.

3.0 Installation Guide

3.1 Window Applications

Top Hung Outward
Opening Window



Bottom Hung Inward
Opening Window



Top Hung Outward
Opening Sill Fix Window



Bottom Hung Outward
Opening Window



Please keep these operating instructions for future reference and maintenance. Subject to technical modifications. Diagram is not binding.

3.2 Top Hung Window Instalation

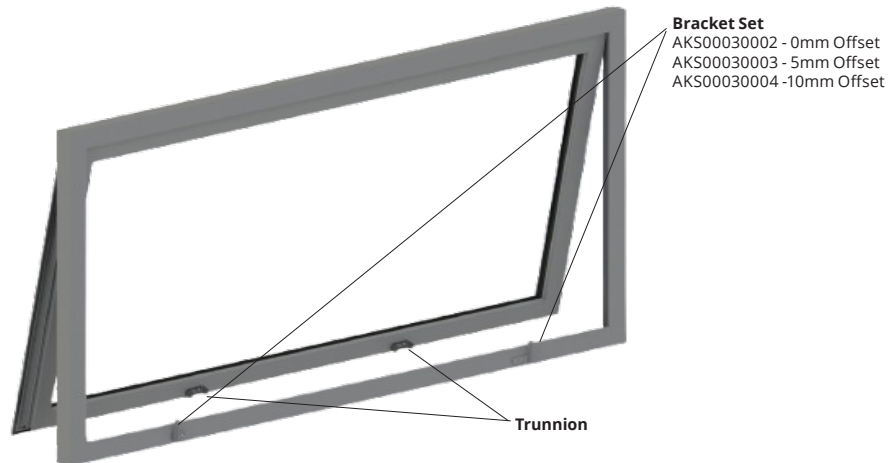

- Fix the trunnion set(2) in the mid position on the moving part of the window using the holding bracket (4) provided.
- Close the window, then fix the chain actuator body(1) with the pivot bracket set(3) provided. It should be aligned with the trunnion set(2) on the moving part of the window. Caution: misalignment will cause improper opening and closing of the window.
- Fix all screws in the trunnion set(2) and pivot bracket(3) firmly. (Make sure sufficient space is allowed for the actuator body to rotate)
- Fix the pin to connect the trunnion set(2) to the top part of the chain.
- Switch on the power supply to test run the actuator for a few cycles, make sure the opening and closing of the window is smooth and free from obstruction.
- Repeat the above if adjustment is required.

*Image for illustration purposes only

3.3 Bottom Hung Window Installation

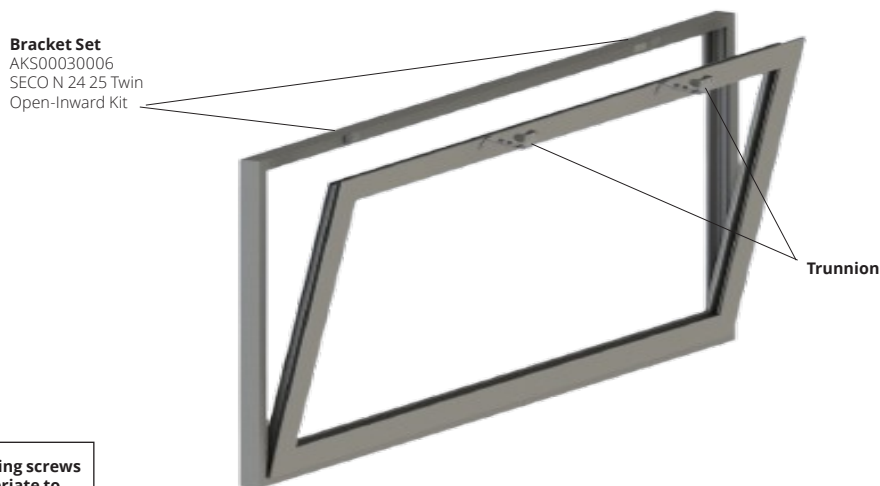

The installation process is similar to the above (Top hung window installation)

Caution: Safety arms chains are recommended to connect to the frame for moving part of the window if bottom hung windows are installed.

*Image for illustration purposes only

3.4 Top Hung Open Out Window Sill Fix Installation

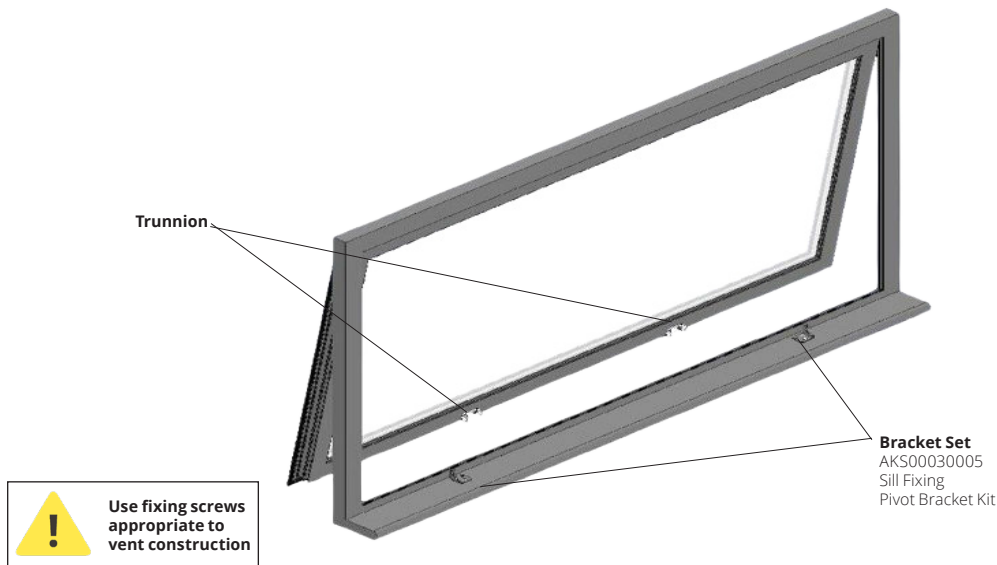

- i. Fix the trunnion set(2) in the mid position on the moving part of the window.
- ii. Close the window, then fix the chain actuator body(1) with the pivot bracket set(3) provided. It should be aligned with the trunnion set(2) on the moving part of the window. Caution: misalignment will cause improper opening and closing of the window.
- iii. Fix all screws in the trunnion set(2) and pivot bracket(3) firmly. (make sure sufficient space is allowed for the actuator body to rotate)
- iv. Fix the pin to connect the trunnion set(2) to the top part of the chain.
- v. Switch on the power supply to test run the actuator for a few cycles, make sure the opening and closing of the window is smooth and free from obstruction

*Image for illustration purposes only

3.5 Setting the Zero Position of the Actuator

(For optimum performance ensure zero point is correctly set)

- i. With the actuator fitted to the vent, run the motor to open and then commence the close of the motor.
- ii. Position the Zero Set Tools (ZST) as shown whilst the motor is running.
- iii. Still holding the ZST in place, allow the vent to close until it stops on current limit MAKING SURE YOU DO NOT TRAP YOUR FINGERS.)
- iv. New zero point is now set. Power and ZST can be removed.

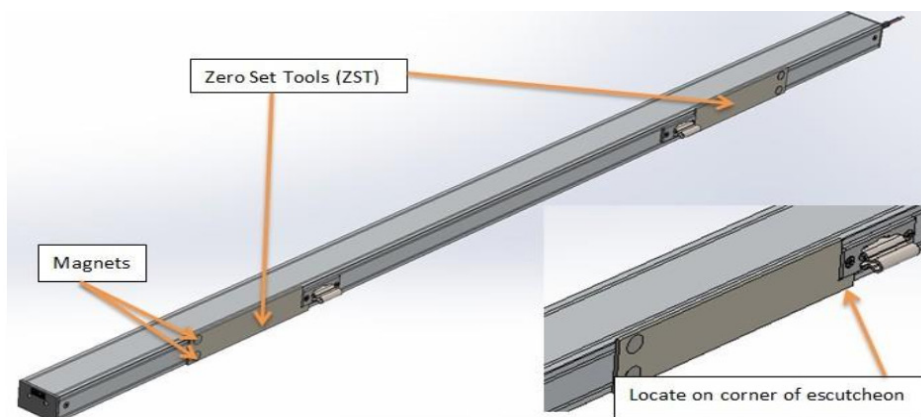

Please keep these operating instructions for future reference and maintenance. Subject to technical modifications. Diagram is not binding.

5.0 Connectivity and Wiring

5.2 Twin SECO N 24 25 to NVLogIQ

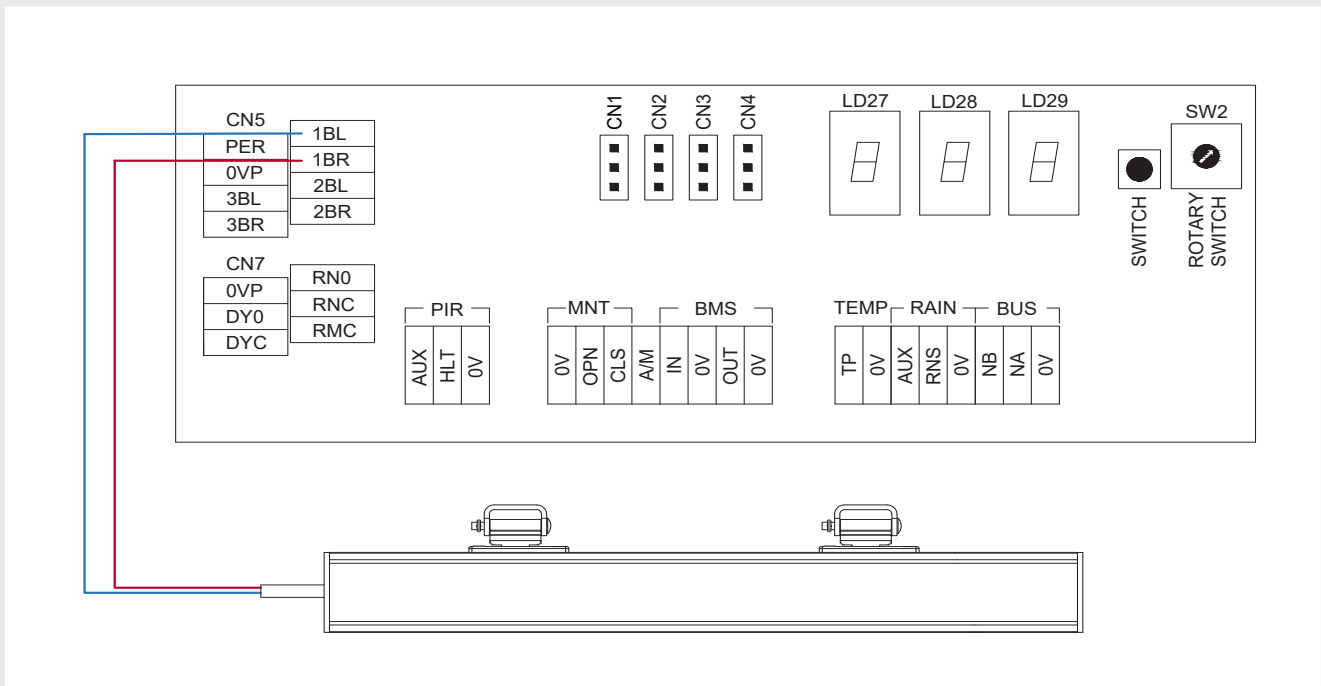

5.3 Twin SECO N 24 25 to 3A Transformer

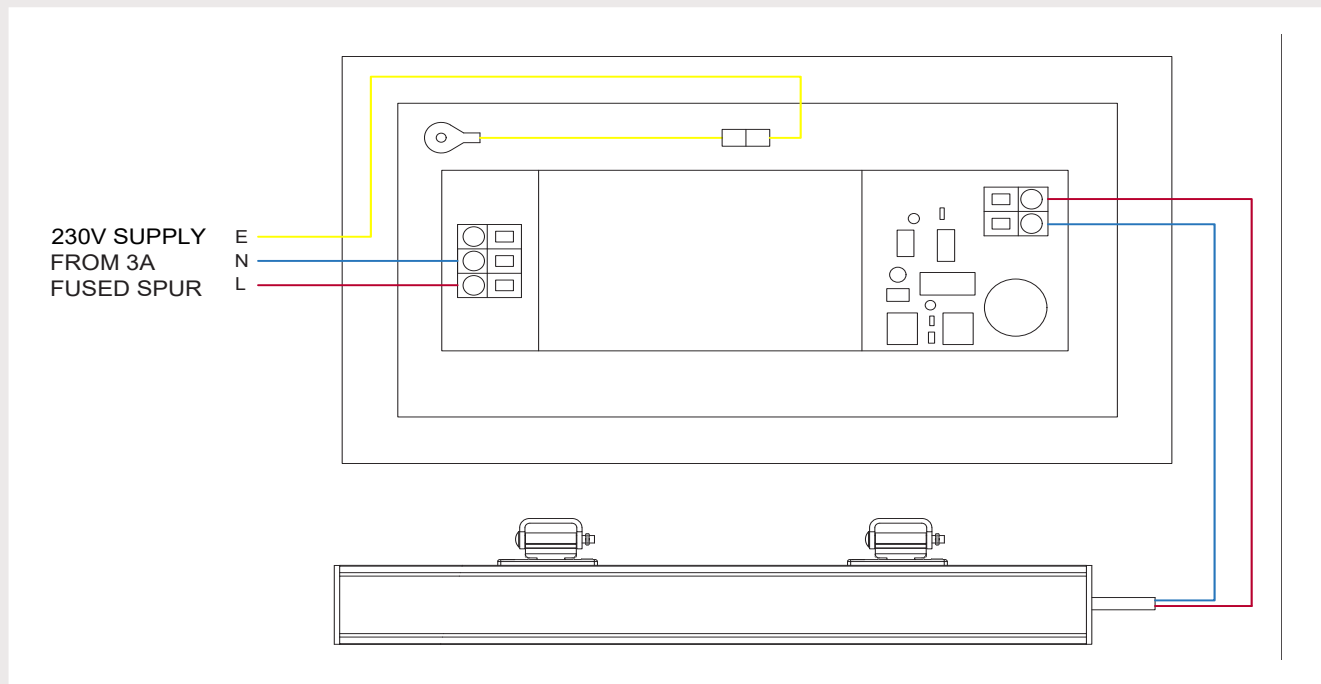

Please keep these operating instructions for future reference and maintenance. Subject to technical modifications. Diagram is not binding.



Creating a healthier & safer environment

Lancaster House
Wellington Crescent
Fradley Park, Lichfield
Staffordshire WS13 8RZ

+44 (0)1543 443060
sales@secontrols.com
www.secontrols.com

