

Tested AOV Solutions for Smoke Ventilation

Tested Solutions and Standard Details



WICONA®

The information in this document is correct at the time of issue, however is subject to change.

Tested AOV Solutions

WICONA



Wicona and SE Controls have collaborated together to provide the fabricator network with a compliant NSHEV AOV to meet the requirements of EN12101-2:2003

The Construction market cannot accept the use of a standard window and 'off the shelf' actuator as an AOV as both must be tested together and manufactured under a System 1 Factory Production Control process to comply. Utilising this tested solution and process detailed below will remove risk from the fabricator of non-compliance in life safety systems.

Compliance to EN12101-2:2003 for smoke vents is mandated by law in the Construction Products Regulation which has been in force since 2013.

The following process has been put in place to support you as a fabricator in placing that product onto the market compliantly

SE Controls Certification Process

STAGE 1 Consult

Consult SE Controls:

- Ensure the system that has been selected is within scope of the tested solution,
- free area performance calculations and to
- select the appropriate tested actuator.

STAGE 2 Fabricate

Fabricate as per the tested solution preparation details and System Company Technical Manual under System 1 FPC to EN 12101-2.

STAGE 3 Installation of Actuators

Installation of actuators (during fabrication or on site) must be carried out under a System 1 FPC process as per the prescriptive detail. Apply certification mark.

STAGE 4 Certify

SE Controls produce a Declaration of Performance (DoP) to EN12101-2:2003 in accordance with BS 7346-8 and the CPR.



As detailed in the certification process the fabricator manufacturing the smoke vents must be audited under a System 1 Factory Production Control Process by a notified body. If you are not already audited and would like to speak to someone about the process please contact our facade technical team - facade.technical@secontrols.com

Alternatively, click [here](#) for our list of audited facade fabricators who can manufacture for you.

Typical AOV Applications



Proof of Compliance

DECLARATION OF PERFORMANCE			
	Document Ref:	SEP-0001-01-01	Date: 15.09.2021
	Project Name:	Block A, High Street, Town	SE Ref: SORD10000
1	Unique Identification Code of Product Type: NSHEV comprising SE Controls SECONI 24 40 Chain Actuator and the System Company, Profile vertical vent		
2	Manufacturing Date Code and Serial Number: As appears on product.		
3	Intended Use: Natural smoke and heat exhaust ventilator for smoke and heat control in construction works.		
4	Name of Manufacturer: SE Controls, Wellington Crescent, Fradley Park, Lichfield, Staffs, UK: WS13 8RZ Tel: +44 (0)1543 443060. Web: www.secontrols.com		
5	Authorised Representatives: Not applicable		
6	System of Assessment and verification of constancy of performance: System 1		
7	Harmonised Standard covered by Construction Products Regulation: EN 12101-2:2003 Smoke and Heat Control Systems - Specification for Natural Smoke and Heat Exhaust Ventilators.		
8	Notified Body: IFC International Certification Ltd., Princes Risborough, HP27 9AH, UK Notified body number: 1720 Performed the initial inspection of the manufacturing plant and of factory production control (FPC), and the continuous surveillance, assessment and evaluation of FPC, and issued the certificate of constancy of performance. Certificate ref 1720-CPR-0001A		
9	Essential Characteristics:		
	Declared performance		EN12101-2:2003
	Terminal Activation Conditions	24v DC	4.3/4.2
	Response Delay	<=5s	7.1.2
	Operational Reliability	1000 / WL1000	7.1/7.4 (Annex C/F)
	Effectiveness of Simular hot gas extraction	C _{sm} : 0.35 to 0.61	6 (Annex B)
	Aerodynamic Free Area	C _{sm} : 0.35 to 0.61	6 (Annex B)
	Performance Criteria under Fire Conditions	B300	7.5 (Annex G)
	Fire Resistance - Mechanical stability	B300	7.5 (Annex G)
	Ability to open under Environmental Conditions	F (00)	7.2/7.3 (Annex I/K)
	Reaction to Fire	AT	7.3.2.1
10	The performance of the product identified in sections 1 and 2 above is in conformity with the declared performance in section 9 above. The declaration of performance is issued under the sole responsibility of the manufacturer identified in section 4 above.		
	Date:	15.09.21	Signed:
	Place of Issue:	Lichfield, UK	Martin Oates - Director of Global Sales

The Declaration of Performance (DoP) and the product certification mark are the ultimate proof of compliance which illustrates the vent profile and actuator have been tested together as a single solution to all declarable essential characteristics of EN12101-2:2003.

The NSHEV is part of a life safety system and the DoP is required at project handover stage in accordance with the CPR and BS7346-8 code of practice.

Ensure that you have this document as it will delay handover if not provided when requested.



Wicona Wicline 65 EN12101-2 Tested Profiles and Parameters

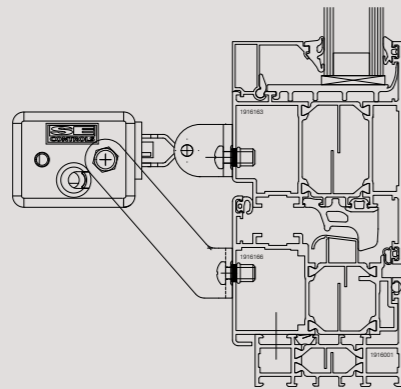

FRAME REF No.	OPENING VENT REF NO.	SERIES 40 BRACKET KIT NO.
1916166	1916163	AKS16000003

System Parameters

ORIENTATION	MAX SASH WIDTH	MAX SASH HEIGHT	MAX SASH WEIGHT
TOP/BOTTOM HUNG ON FRICTION HINGES	2000MM	2500MM	120KG
	2500MM	1500MM	
TOP/BOTTOM HUNG ON BUTT HINGES	1500MM	2500MM	120KG
	2500MM	1500MM	
SIDE HUNG ON BUTT HINGES	1700MM	2500MM	100KG

Max Certifiable Weight = 120KG, Max Certifiable Perimeter = 7.1 Metres

Butt hinges are the preferred hardware for AOV's. Please contact Wicona's technical team for confirmation of suitable hardware

Wicona Wicline 75 EN12101-2 Tested Profiles and Parameters

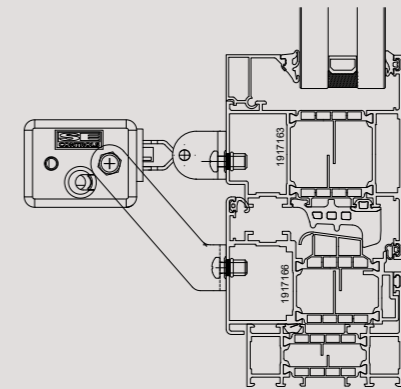

FRAME REF No.	OPENING VENT REF NO.	SERIES 40 BRACKET KIT NO.
1917166	1917163	AKS16000003

System Parameters

ORIENTATION	MAX SASH WIDTH	MAX SASH HEIGHT	MAX SASH WEIGHT
TOP/BOTTOM HUNG ON FRICTION HINGES	2000MM	2500MM	120KG
	2500MM	1500MM	
TOP/BOTTOM HUNG ON BUTT HINGES	1500MM	2500MM	120KG
	2500MM	1500MM	
SIDE HUNG ON BUTT HINGES	1700MM	2500MM	100KG

Max Certifiable Weight = 120KG, Max Certifiable Perimeter = 7.1 Metres

Butt hinges are the preferred hardware for AOV's. Please contact Wicona's technical team for confirmation of suitable hardware



Wicona Wicline 90SG EN12101-2 Tested Profiles and Parameters

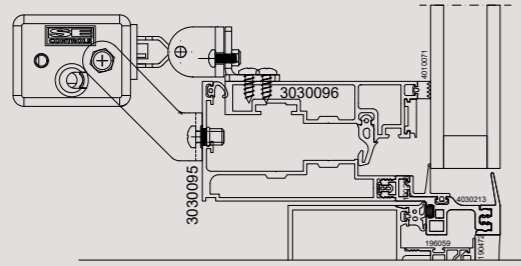

FRAME REF NO.	OPENING VENT REF NO.	SERIES 40 BRACKET KIT NO.	SERIES 40 TRUNNION BRACKET NO.
3030095	3030096	AKS16100001	ABS01000241

System Parameters

ORIENTATION	MAX SASH WIDTH	MAX SASH HEIGHT	MAX SASH WEIGHT
TOP HUNG ON FRICTION STAYS	2000MM	1700MM	120KG

Max Certifiable Weight = 120KG, Max Certifiable Perimeter = 7.1 Metres

Notes

The profile parameters outlined within this document are aligned to Wicona tested performance parameters. If your vents are outside of these sizes please ensure you obtain written acceptance from Wicona for the oversized vents. Without this we cannot produce a Declaration of Performance.

The actuators alone will not act as 'window restrictors'. The façade contractor/fabricator should consider the installation of suitable restrictors relative to the orientation of the vent, so that stability is provided should the actuator be removed, or the vent is subjected to high external forces whilst in the open position. Contact our team for further advice.

Please ensure that the latest Wicona Technical Manual is followed during fabrication of the vents. Any deviation from the technical manual must be discussed with SE Controls prior to fabrication

Façade Engineering Services

CAD DETAILS	PROJECT DESIGN
CERTIFICATION	QUOTATIONS
FREE AREA CALCULATIONS	REGULATIONS ADVICE
PRODUCT SELECTION	SPECIFICATION

To contact a member of the Façade support team [click here](#).

For further information [click here](#) for the Smoke Control Association's guidance document for EN12101-2:2003 Automatic Opening Smoke Vents.

